



Product Specification

7.0" TFT LCD Module

Model No :	AGO 070J0-NN-N
Resolution:	800 X480
Interface:	RGB 50PIN
Luminance:	420cd/m ²

< ◇ > Preliminary Specification

< ◆ > Finally Specification

CUSTOMER'S APPROVAL	
CUSTOMER :	
SIGNATURE:	DATE:

APPROVED BY	PM REVIEWED	PD REVIEWED	PREPARED BY



Table of Contents

No.	Item	Page
1.	General Description	4
2.	Module Parameter.....	4
3.	Absolute Maximum Ratings.....	4
4.	DC Characteristics	5
5.	Backlight Characteristic.....	5
5.1.	Backlight Characteristics.....	5
5.2.	Backlighting circuit.....	5
6.	Optical Characteristics	6
6.1.	Optical Characteristics.....	6
6.2.	Definition of Response Time.....	6
6.3.	Definition of Contrast Ratio	7
6.4.	Definition of Viewing Angles.....	7
6.5.	Definition of Color Appearance	7
6.6.	Definition of Surface Luminance, Uniformity and Transmittance	8
7.	Block Diagram and Power Supply	9
8.	Interface Pins Definition	10
9.	Timing Characteristics.....	12
9.1.	AC Electrical Characteristics.....	12
9.2.	Input Clock and Data Timing Diagram.....	12
9.3.	Timing	13
9.4.	Data Input Format.....	13
9.5.	Power Sequence	14
10.	Quality Assurance	15
10.1	Purpose.....	15
10.2	Standard for Quality Test	15
10.3	Nonconforming Analysis & Disposition	15
10.4	Agreement Items	16
10.5	Standard of the Product Visual Inspection.....	16
10.6	Inspection Specification	16
10.7	Classification of Defects.....	20
10.8	Identification/marketing criteria	20
10.9	Packing	20
11.	Reliability Specification.....	21
12.	Precautions and Warranty.....	22
12.1.	Safety.....	22
12.2.	Handling.....	22
12.3.	Storage	22
12.4.	Metal Pin (Apply to Products with Metal Pins)	22
12.5.	Operation	23
12.6.	Static Electricity	23
12.7.	Limited Warranty	23
13.	Outline Drawing	24



1. General Description

The specification is a transmissive type color active matrix liquid crystal display (LCD) which uses amorphous thin film transistor (TFT) as switching devices. This product is composed of a TFT-LCD panel, driver ICs and a backlight unit.

2. Module Parameter

Features	Details	Unit
Display Size (Diagonal)	7.0"	
LCD type	TN TFT	
Display Mode	Transmissive/Normal White	
Resolution	800 RGB x 480	Pixels
View Direction	12 O'clock	Best Image
Gray Scale Inversion Direction	6 O'clock	
Module Outline	164.9(H) x 100(V) x 5.7(T) (Note1)	mm
Active Area	154.08(H) x 85.92(V)	mm
Pixel Size	192.6(H) x 179(V)	um
Pixel Arrangement	R.G.B Stripe	
Polarizer Surface Treatment	Anti-glare	
Display Colors	16.7M	
Interface	24 Bit RGB	
With or Without Touch Panel	Without	
Operating Temperature	-20~70	°C
Storage Temperature	-30~80	°C
Weight	150	g

Note 1: Exclusive hooks, posts, FFC/FPC tail, etc.

3. Absolute Maximum Ratings

$V_{SS}=0V$, $T_a=25^{\circ}C$

Item	Symbol	Min.	Max.	Unit
Supply Voltage	VCC	-0.3	5.0	V
Storage Temperature	T _{STG}	-30	80	°C
Operating Temperature	T _{OP}	-20	70	°C

Note 1: If T_a below $50^{\circ}C$, the maximal humidity is 90%RH, if T_a over $50^{\circ}C$, absolute humidity should be less than 60%RH.

Note 2: The response time will be extremely slow when the operating temperature is around $-10^{\circ}C$, and the background will become darker at high temperature operating.



4. DC Characteristics

Item	Symbol	Min.	Typ.	Max.	Unit
Digital Power Supply Voltage	DVDD	3.0	3.3	3.6	V
Analog Power Supply Voltage	AVDD	10.2	10.4	10.6	V
TFT Device ON Voltage	V _{GH}	15.3	16.0	16.7	V
TFT Device OFF Voltage	V _{GL}	-7.7	-7.0	-6.3	V
Common Electrode Driving Voltage	V _{COM}	2.6	3.6	4.6	V
Low Level Input Voltage	V _{IL}	0	-	0.3*DVDD	V
High Level Input Voltage	V _{IH}	0.7*DVDD	-	DVDD	V

5. Backlight Characteristic

5.1. Backlight Characteristics

Item	Symbol	Condition	Min	Typ	Max	Unit
Forward Voltage	V _F	T _a =25 °C, I _F =20mA/LED	8.4	9.3	10.2	V
Forward Current	I _F	T _a =25 °C, V _F =3.1V/LED	-	180	-	mA
Power Dissipation	P _D		-	1.674	-	W
Uniformity	Avg		70	75	-	%
LED Working Life (25°C)	-		-	30000	-	Hrs
Drive Method	Constant Current					
LED Configuration	27 White LEDs (3 LEDs in one string and 9groups in parallel)					

Note1: LED lifetime defined as follows: The final brightness is at 50% of original brightness. The environmental conducted under ambient air flow, at T_a=25 ± 2 °C, 60%RH ± 5%, I_F=20mA

5.2. Backlighting circuit

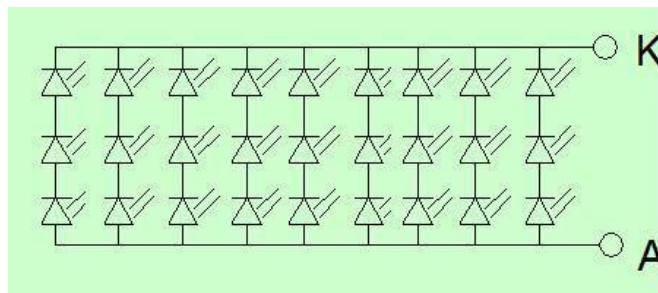



6. Optical Characteristics

6.1. Optical Characteristics

Ta=25°C, DVDD=3.3V

	Item	Symbol	Condition	Specification			Unit	
				Min.	Typ.	Max.		
Backlight On (Transmissive Mode)	Luminance on TFT(I _f =20mA/LED)	L _v	Normally viewing angle θ _x =φ _y =0°	400	420	-	cd/m ²	
	Contrast ratio (See 6.3)	CR		-	500	-		
	Response time (See 6.2)	T _R		-	10	20	ms	
		T _F	-	15	30			
	Chromaticity Transmissive (See 6.5)	Red	X _R	Center CR≥10	0.524	0.574	0.624	
			Y _R		0.290	0.340	0.390	
		Green	X _G		0.272	0.322	0.372	
			Y _G		0.556	0.606	0.656	
		Blue	X _B		0.091	0.141	0.191	
			Y _B		0.040	0.090	0.140	
	White	X _W	0.244	0.294	0.344			
		Y _W	0.286	0.336	0.386			
	Viewing Angle (See 6.4)	Horizontal	θ _{x+}	Center CR≥10	60	70	-	Deg.
θ _{x-}			60		70	-		
Vertical		φ _{y+}	40		50	-		
		φ _{y-}	60		70	-		

6.2. Definition of Response Time

6.2.1. Normally Black Type (Negative)

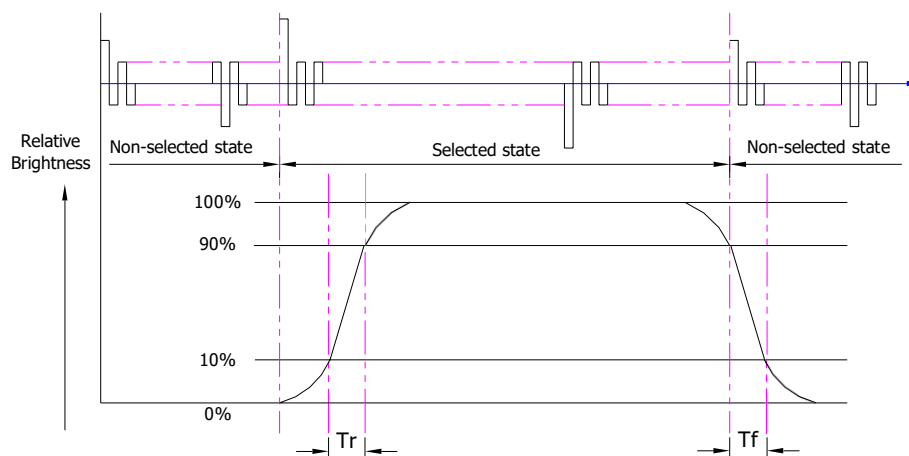

Tr is the time it takes to change from non-selected state with relative luminance 10% to selected state with relative luminance 90%.

Tf is the time it takes to change from selected state with relative luminance 90% to non-selected state with relative luminance 10%.

Note : Measuring machine: LCD-5100



6.2.2. Normally White Type (Positive)

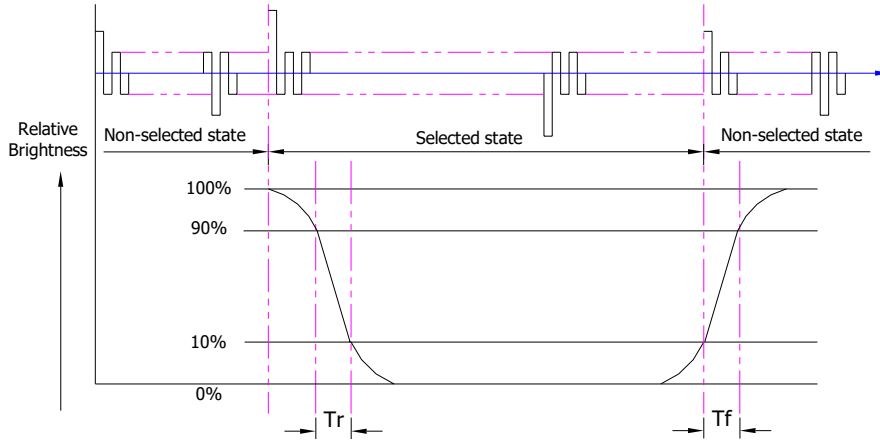

T_r is the time it takes to change from non-selected state with relative luminance 90% to selected state with relative luminance 10%;

T_f is the time it takes to change from selected state with relative luminance 10% to non-selected state with relative luminance 90%;

Note : Measuring machine: LCD-5100 or EQUI

6.3. Definition of Contrast Ratio

Contrast is measured perpendicular to display surface in reflective and transmissive mode. The measurement condition is:

Measuring Equipment	Eldim or Equivalent
Measuring Point Diameter	3mm//1mm
Measuring Point Location	Active Area centre point
Test pattern	A: All Pixels white
	B: All Pixel black
Contrast setting	Maximum

Definitions: CR (Contrast) = Luminance of White Pixel / Luminance of Black Pixel

6.4. Definition of Viewing Angles

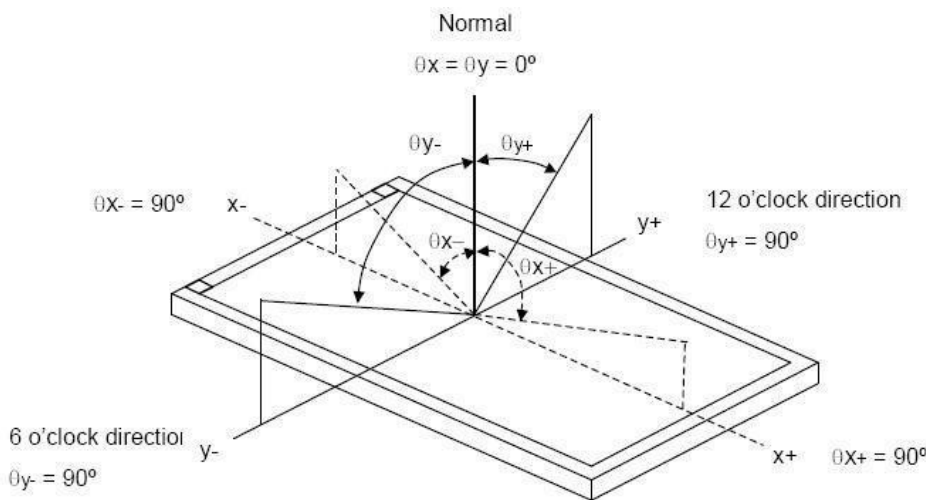

Measuring machine: LCD-5100 or EQUI

6.5. Definition of Color Appearance

R,G,B and W are defined by (x, y) on the IE chromaticity diagram

NTSC=area of RGB triangle/area of NTSC triangleX100%

Measuring picture: Red, Green, Blue and White (Measuring machine: BM-7)

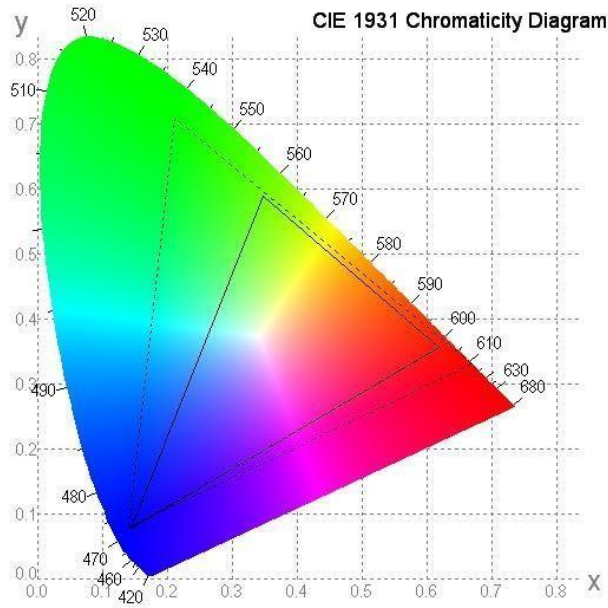

6.6. Definition of Surface Luminance, Uniformity and Transmittance

Using the transmissive mode measurement approach, measure the white screen luminance of the display panel and backlight.

- 6.6.1. Surface Luminance: $L_V = \text{Average } (L_{P1}:L_{P9})$
- 6.6.2. Uniformity = $\text{Minimal } (L_{P1}:L_{P9}) / \text{Maximal } (L_{P1}:L_{P9}) * 100\%$
- 6.6.3. Transmittance = $L_V \text{ on LCD} / L_V \text{ on Backlight} * 100\%$

Note : Measuring Machine: BM-7

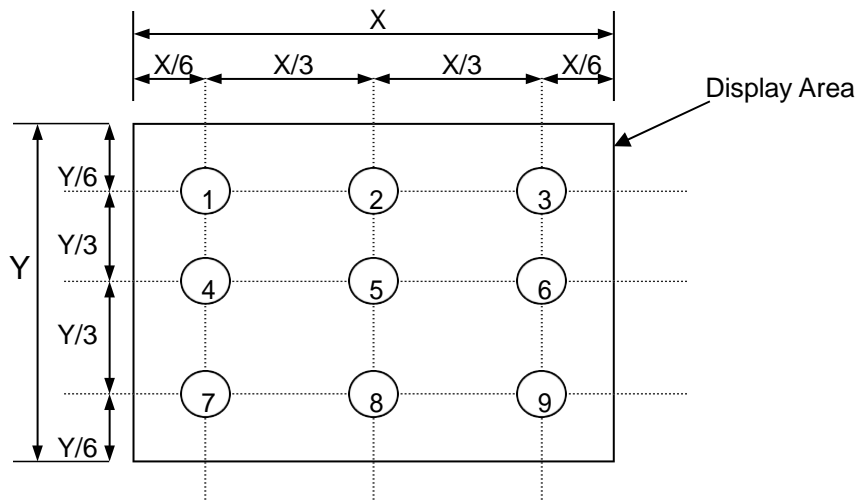



7. Block Diagram and Power Supply

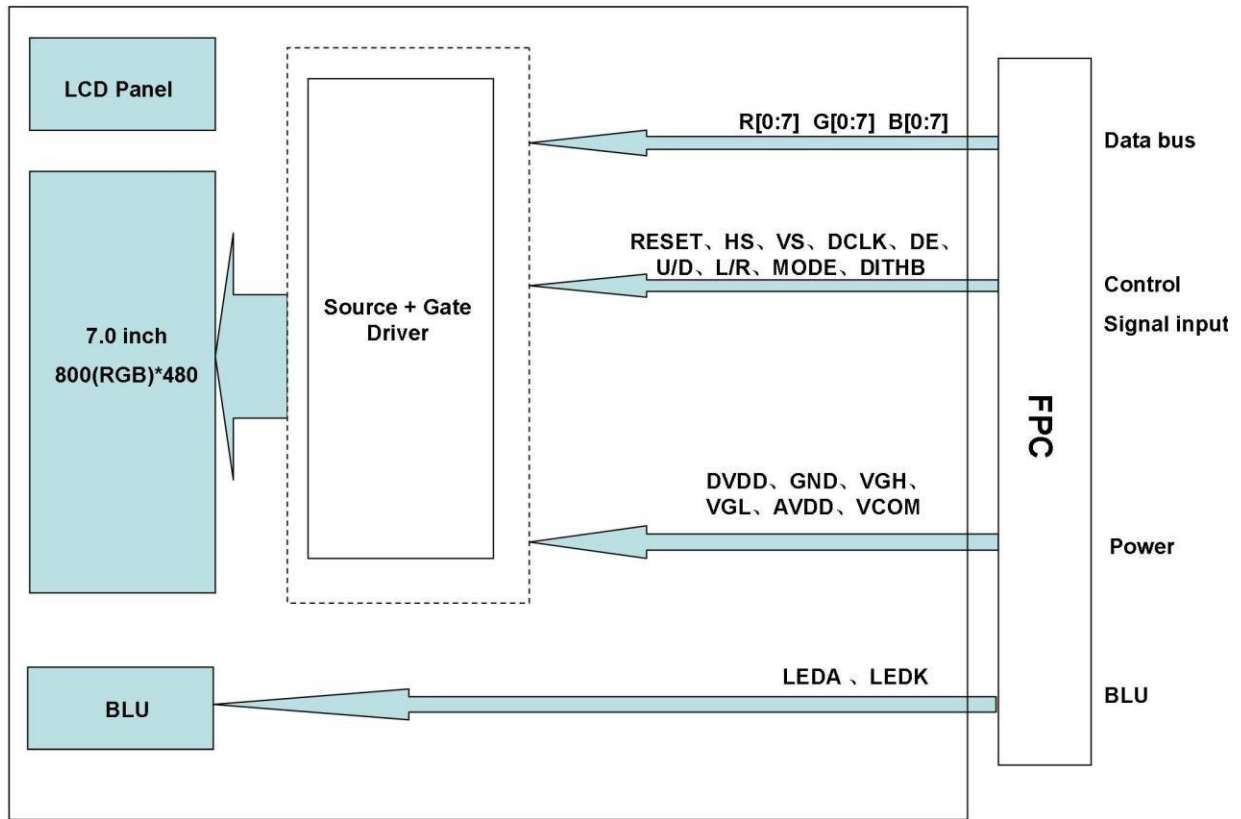



No.	Symbol	Function	Remark
1	LEDA	Led anode	
2	LEDA	Led anode	
3	LEDK	Led cathode	
4	LEDK	Led cathode	
5	GND	Ground	
6	VCOM	Common voltage input	
7	DVDD	Digital power supply	
8	MODE	DE/SYNC mode select. H:DE mode, L:SYNC mode	
9	DE	Data enable signal, active high to enable data	
10	VS	Vertical sync input, negative polarity	
11	HS	Horizontal sync input, negative polarity	
12	B7	Blue data (MSB)	
13	B6	Blue data	
14	B5	Blue data	
15	B4	Blue data	
16	B3	Blue data	
17	B2	Blue data	
18	B1	Blue data	
19	B0	Blue data (LSB)	
20	G7	Green data (MSB)	
21	G6	Green data	
22	G5	Green data.	
23	G4	Green data	
24	G3	Green data	
25	G2	Green data	
26	G1	Green data.	
27	G0	Green data (LSB)	
28	R7	Red data (MSB)	
29	R6	Red data	
30	R5	Red data	
31	R4	Red data	
32	R3	Red data	
33	R2	Red data	
34	R1	Red data	
35	R0	Red data (LSB)	
36	GND	Ground	
37	DCLK	Clock for input data	
38	GND	Ground	
39	L/R	Source left or right sequence control	
40	U/D	Gate up or down scan control	
41	VGH	Positive power of TFT	
42	VGL	Negative power of TFT	
43	AVDD	Analog power supply	



44	RESET	Global reset pin	
45	NC	No connection	
46	VCOM	Common voltage input	
47	DITHB	Dithering setting. H: 6bit resolution, L: 8bit resolution	
48	GND	Ground	
49	NC	No connection	
50	NC	No connection	

8. Interface Pins Definition

Note 1: DE/SYNC mode select. Normally pull high.

When select DE mode, MODE="1", VS and HS must pull high.

When select SYNC mode, MODE="0", DE must be grounded.

Note 2: When input 18 bits RGB data, the two low bits of R, G and B data must be grounded.

Note 3: Data shall be latched at the falling edge of DCLK.

Note 4: Selection of scanning mode

Setting of scan control input		Scanning direction
U/D	L/R	
GND	DVDD	Up to down, left to right
DVDD	GND	Down to up, right to left
GND	GND	Up to down, right to left
DVDD	DVDD	Down to up, left to right

Note 5: Definition of scanning direction.

Refer to the figure as below:

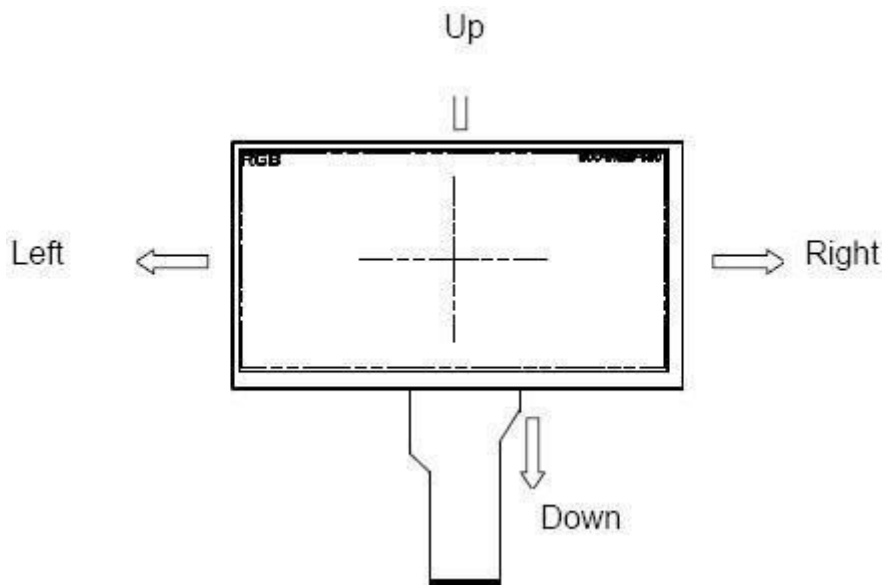

Note 6: Global reset pin. Active low to enter reset state. Suggest to connect with an RC reset circuit for stability. Normally pull high.

Note 7: Dithering function enable control, normally pull high.

When DITHB="1", Disable internal dithering function.

When DITHB="0", Enable internal dithering function.



9. Timing Characteristics

9.1. AC Electrical Characteristics

Item	Symbol	Values			Unit	Remark
		Min.	Typ.	Max.		
HS setup time	T_{hst}	8	-	-	ns	
HS hold time	T_{hhd}	8	-	-	ns	
VS setup time	T_{vst}	8	-	-	ns	
VS hold time	T_{vhd}	8	-	-	ns	
Data setup time	T_{dsu}	8	-	-	ns	
Data hole time	T_{dhd}	8	-	-	ns	
DE setup time	T_{esu}	8	-	-	ns	
DE hole time	T_{ehd}	8	-	-	ns	
DV _{DD} Power On Slew rate	T_{POR}	-	-	20	ms	From 0 to 90% DV _{DD}
RESET pulse width	T_{Rst}	1	-	-	ms	
DCLK cycle time	T_{coh}	20	-	-	ns	
DCLK pulse duty	T_{cwh}	40	50	60	%	

9.2. Input Clock and Data Timing Diagram

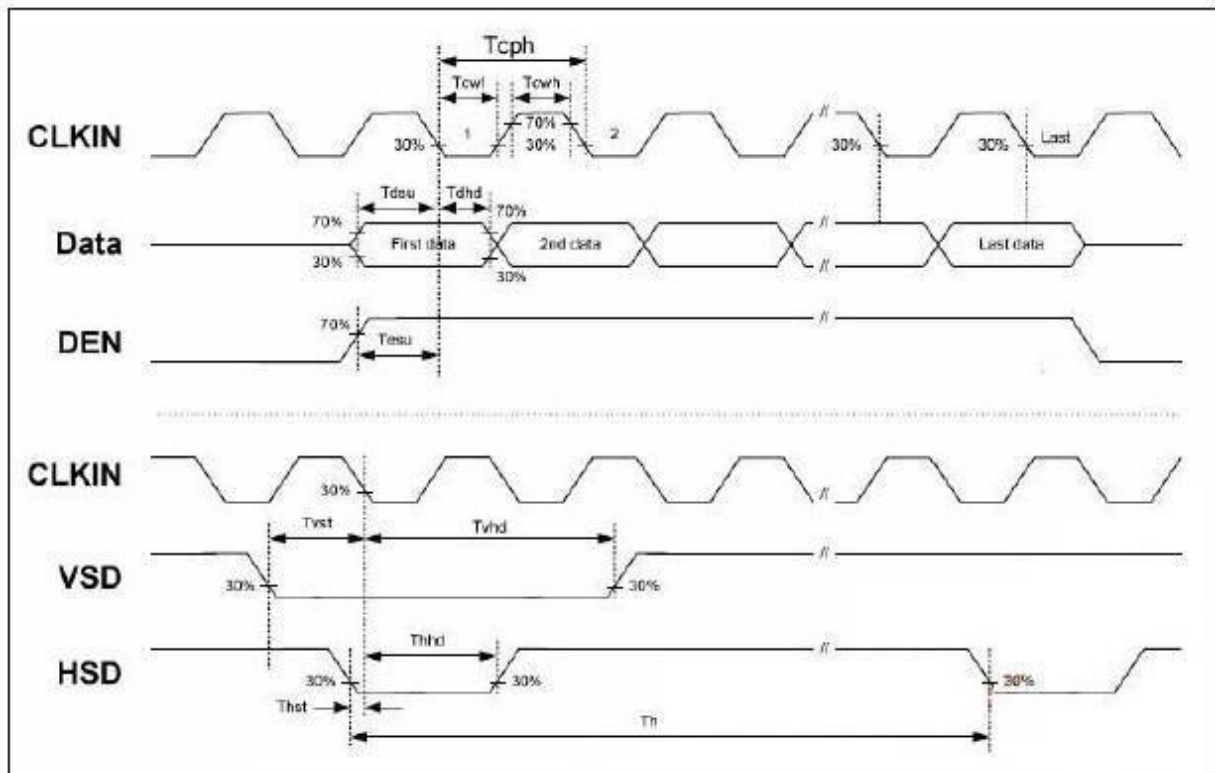



9.3. Timing

Item	Symbol	Values			Unit	Remark
		Min.	Typ.	Max.		
Horizontal Display Area	thd	-	800	-	DCLK	
DCLK Frequency	fclk	26.4	33.3	46.8	MHz	
One Horizontal Line	th	862	1056	1200	DCLK	
HS pulse width	thpw	1	-	40	DCLK	
HS Blanking	thb	46	46	46	DCLK	
HS Front Porch	thfp	16	210	354	DCLK	

Item	Symbol	Values			Unit	Remark
		Min.	Typ.	Max.		
Vertical Display Area	tvd	-	480	-	TH	
VS period time	tv	510	525	650	TH	
VS pulse width	tvpw	1	-	20	TH	
VS Blanking	tvb	23	23	23	TH	
VS Front Porch	tvfp	7	22	147	TH	

9.4. Data Input Format

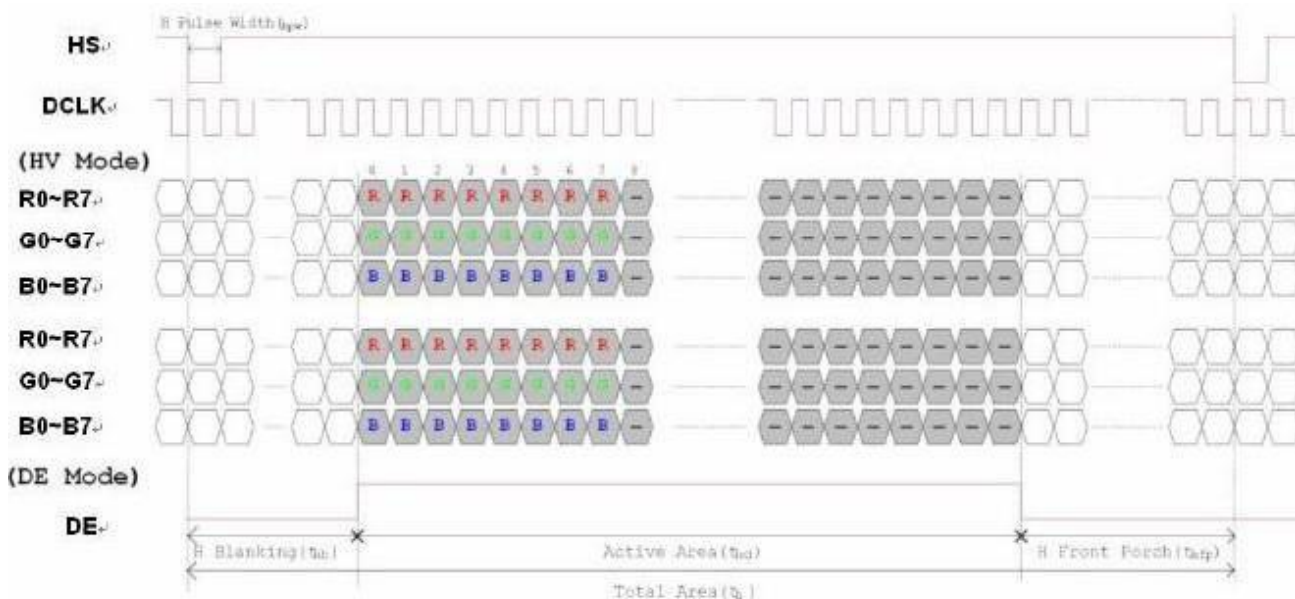



Horizontal input timing diagram

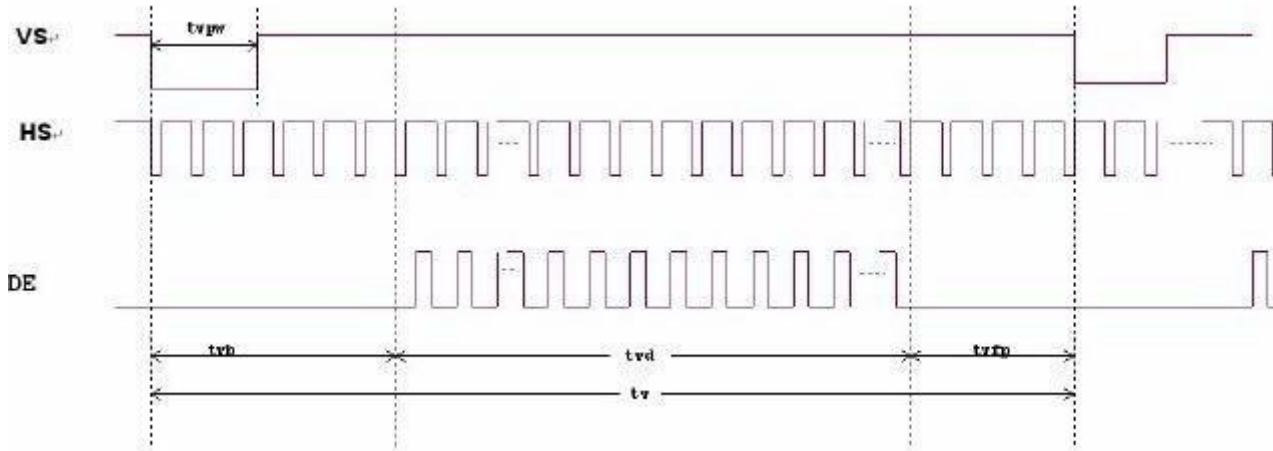

Vertical input timing diagram

9.5. Power Sequence

a. Power on:

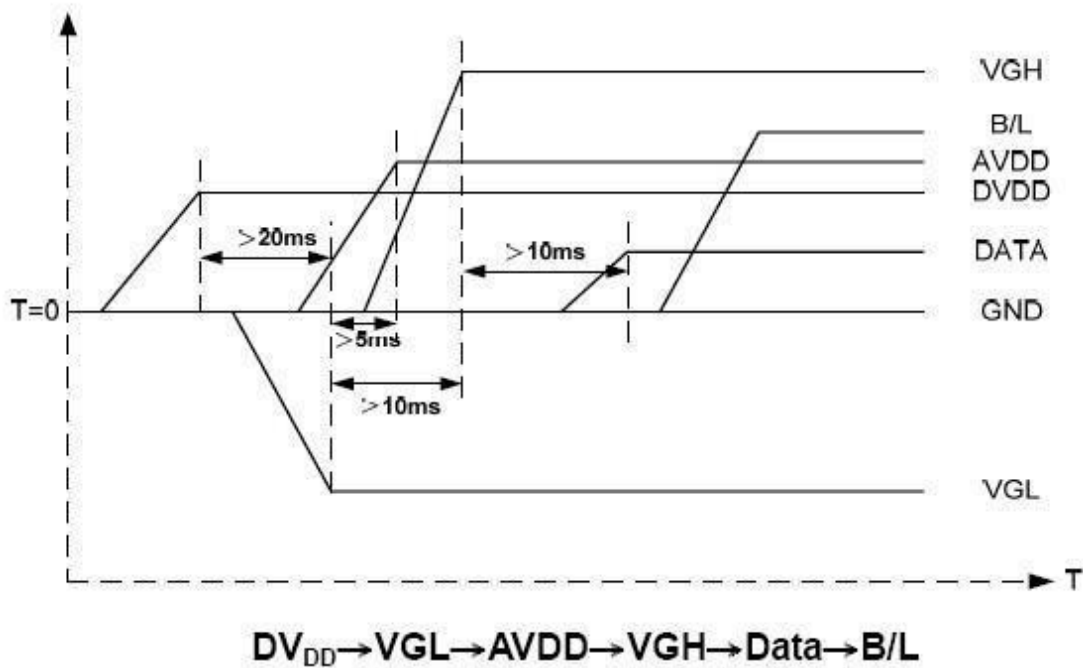



b. Power off:

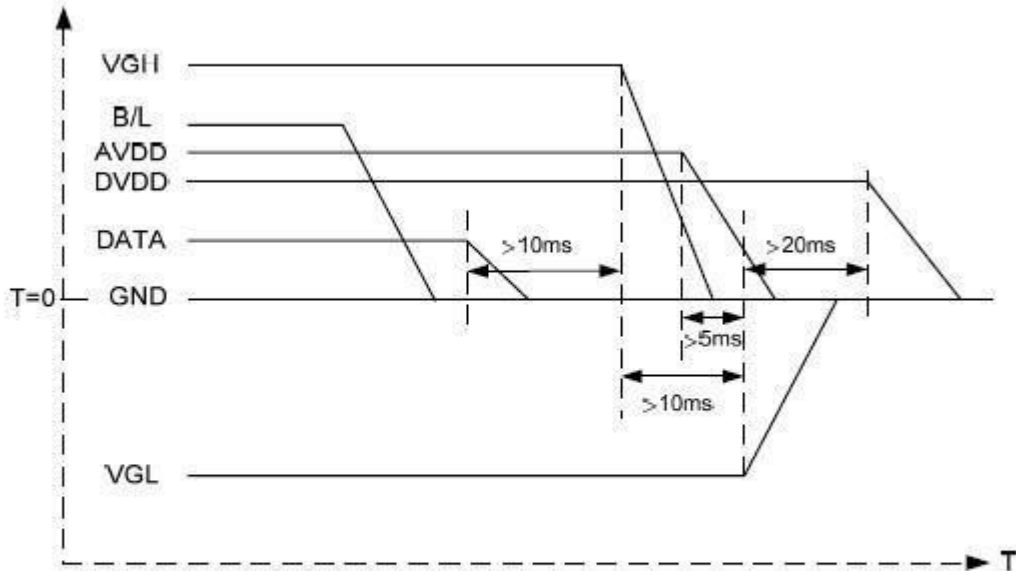

B/L→Data→VGHI→AVDD→VGL→DV_{DD}

Note: Data include R0~R7, B0~B7, G0~G7, U/D, L/R, DCLK, HS, VS, DE.

10. Quality Assurance

10.1 Purpose

This standard for Quality Assurance assures the quality of LCD module products supplied to customer.

10.2 Standard for Quality Test

10.2.1 Sampling Plan:

GB2828.1-2012.

Single sampling, normal inspection.

10.2.2 Sampling Criteria:

Visual inspection: AQL 1.5%

Electrical functional: AQL 0.65%.

10.2.3 Reliability Test:

Detailed requirements refer to Reliability Test Specification.

10.3 Nonconforming Analysis & Disposition

10.3.1 Nonconforming analysis:

10.3.1.1 Customer should provide overall information of non-conforming sample for their complaints.

10.3.1.2 After receipt of detailed information from customer, the analysis of nonconforming parts usually should be finished in one week.

10.3.1.3 If cannot finish the analysis on time, customer will be notified with the progress status.

10.3.2 Disposition of nonconforming:

10.3.2.1 Non-conforming product over PPM level will be replaced.



10.3.2.2 The cause of non-conformance will be analyzed. Corrective action will be discussed and implemented.

10.4 Agreement Items

Shall negotiate with customer if the following situation occurs:

- 10.4.1 There is any discrepancy in standard of quality assurance.
- 10.4.2 Additional requirement to be added in product specification.
- 10.4.3 Any other special problem.

10.5 Standard of the Product Visual Inspection

10.5.1 Appearance inspection:

- 10.5.1.1 The inspection must be under illumination about 1000 – 1500 lx, and the distance of view must be at 30cm ± 2cm.
- 10.5.1.2 The viewing angle should be 45° from the vertical line without reflection light or follows customer's viewing angle specifications.
- 10.5.1.3 Definition of area: A Zone: Active Area, B Zone: Viewing Area,

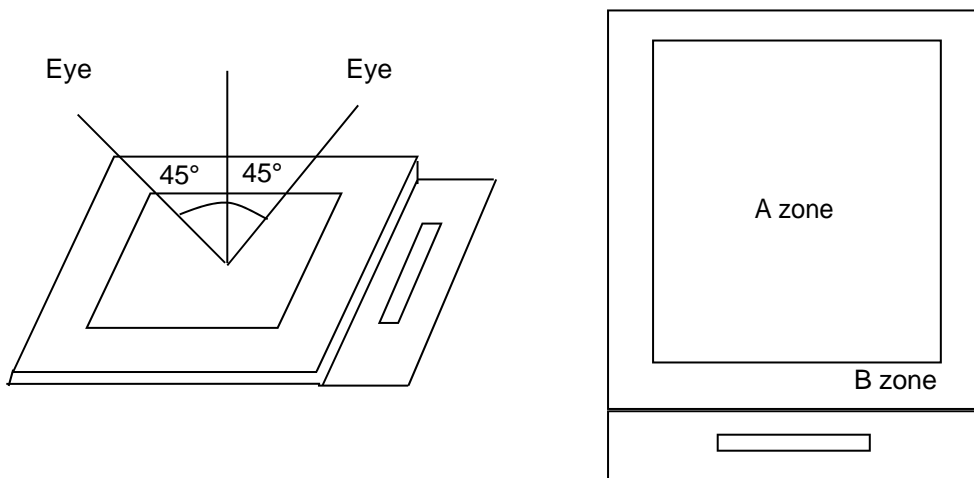

10.5.2 Basic principle:

- 10.5.2.1 A set of samples to indicate the limit of acceptable quality level must be discussed by both us and customer when there is any dispute happened.
- 10.5.2.2 New item must be added on time when it is necessary.

10.6 Inspection Specification

No.	Item	Criteria (Unit: mm)
-----	------	---------------------

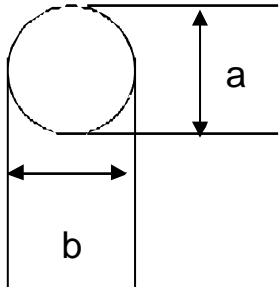

01	Black / White spot Foreign material (Round type) Pinholes Stain Particles inside cell. (Minor defect)		<table border="1"> <tr> <td>Area</td> <td>Acc. Qty</td> </tr> <tr> <td>$\phi \leq 0.20$</td> <td>Ignore</td> </tr> <tr> <td>$0.20 < \phi \leq 0.50$</td> <td>$N \leq 3$</td> </tr> <tr> <td>$0.50 < \phi$</td> <td>0</td> </tr> </table>	Area	Acc. Qty	$\phi \leq 0.20$	Ignore	$0.20 < \phi \leq 0.50$	$N \leq 3$	$0.50 < \phi$	0
		Area	Acc. Qty								
$\phi \leq 0.20$	Ignore										
$0.20 < \phi \leq 0.50$	$N \leq 3$										
$0.50 < \phi$	0										
$\phi = (a + b) / 2$ Distance between 2 defects should more than 5mm apart.											

02	Electrical Defect (Minor defect)	<table border="1"> <tr> <th>Bright dot</th> <th>Display Area</th> <th>Total</th> <th rowspan="3">Note 1</th> </tr> <tr> <td></td> <td>$N \leq 2$</td> <td>$N \leq 2$</td> </tr> <tr> <th>Dark dot</th> <td>$N \leq 4$</td> <td>$N \leq 4$</td> </tr> <tr> <th>Total dot</th> <td>$N \leq 4$</td> <td>$N \leq 4$</td> <td></td> </tr> </table>	Bright dot	Display Area	Total	Note 1		$N \leq 2$	$N \leq 2$	Dark dot	$N \leq 4$	$N \leq 4$	Total dot	$N \leq 4$	$N \leq 4$	
		Bright dot	Display Area	Total	Note 1											
			$N \leq 2$	$N \leq 2$												
		Dark dot	$N \leq 4$	$N \leq 4$												
Total dot	$N \leq 4$	$N \leq 4$														
<table border="1"> <tr> <th>Mura</th> <td colspan="2">Not visible through 5% ND filters.</td> <td>Note 2</td> </tr> </table>	Mura	Not visible through 5% ND filters.		Note 2												
Mura	Not visible through 5% ND filters.		Note 2													
Remark: 1. Bright dot caused by scratch and foreign object accords to item 1.																

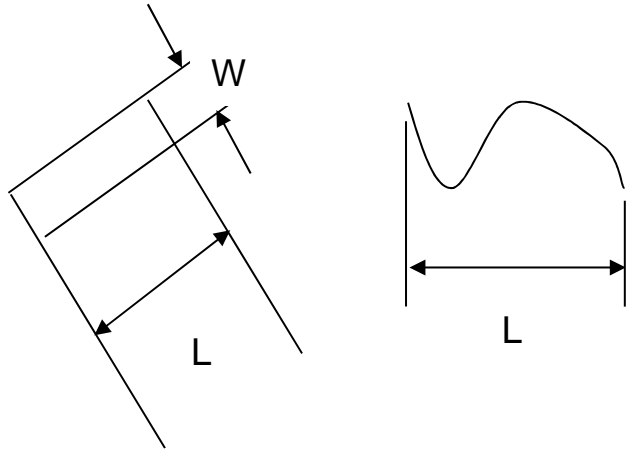
03	Black and White line Scratch Foreign material (Line type) (Minor defect)														
		<table border="1"> <tr> <th>Length</th> <th>Width</th> <th>Acc. Qty</th> </tr> <tr> <td>/</td> <td>$W \leq 0.1$</td> <td>Ignore</td> </tr> <tr> <td>$L \leq 2.5$</td> <td>$0.1 < W \leq 0.2$</td> <td>3</td> </tr> <tr> <td>$L > 2.5$</td> <td>$0.2 < W$</td> <td>0</td> </tr> <tr> <td colspan="2">Total</td> <td>3</td> </tr> </table>	Length	Width	Acc. Qty	/	$W \leq 0.1$	Ignore	$L \leq 2.5$	$0.1 < W \leq 0.2$	3	$L > 2.5$	$0.2 < W$	0	Total
Length	Width	Acc. Qty													
/	$W \leq 0.1$	Ignore													
$L \leq 2.5$	$0.1 < W \leq 0.2$	3													
$L > 2.5$	$0.2 < W$	0													
Total		3													
Distance between 2 defects should more than 3mm apart. Scratches not viewable through the back of the display are acceptable.															

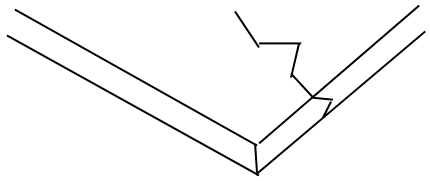

04	Glass Crack (Minor defect)	 <p>Crack is potential to enlarge, any type is not allowed.</p>
----	-------------------------------	--

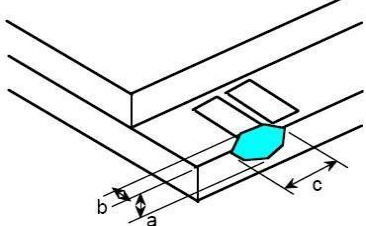
05	Glass Chipping Pad Area: (Minor defect)	 <table border="1" data-bbox="774 649 1244 817"> <thead> <tr> <th>Length and Width</th> <th>Acc. Qty</th> </tr> </thead> <tbody> <tr> <td>$c > 3.0, b < 1.0$</td> <td>1</td> </tr> <tr> <td>$c < 3.0, b < 1.0$</td> <td>3</td> </tr> <tr> <td colspan="2">$a < \text{Glass Thickness}$</td> </tr> </tbody> </table>	Length and Width	Acc. Qty	$c > 3.0, b < 1.0$	1	$c < 3.0, b < 1.0$	3	$a < \text{Glass Thickness}$	
Length and Width	Acc. Qty									
$c > 3.0, b < 1.0$	1									
$c < 3.0, b < 1.0$	3									
$a < \text{Glass Thickness}$										

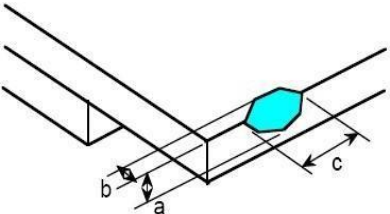
06	Glass Chipping Rear of Pad Area: (Minor defect)	 <table border="1" data-bbox="774 1041 1244 1254"> <thead> <tr> <th>Length and Width</th> <th>Acc. Qty</th> </tr> </thead> <tbody> <tr> <td>$c > 3.0, b < 1.0$</td> <td>1</td> </tr> <tr> <td>$c < 3.0, b < 1.0$</td> <td>2</td> </tr> <tr> <td>$c < 3.0, b < 0.5$</td> <td>4</td> </tr> <tr> <td colspan="2">$a < \text{Glass Thickness}$</td> </tr> </tbody> </table>	Length and Width	Acc. Qty	$c > 3.0, b < 1.0$	1	$c < 3.0, b < 1.0$	2	$c < 3.0, b < 0.5$	4	$a < \text{Glass Thickness}$	
Length and Width	Acc. Qty											
$c > 3.0, b < 1.0$	1											
$c < 3.0, b < 1.0$	2											
$c < 3.0, b < 0.5$	4											
$a < \text{Glass Thickness}$												

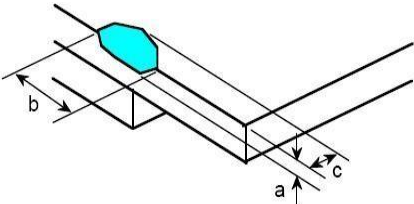
07	Glass Chipping Except Pad Area: (Minor defect)	 <table border="1" data-bbox="774 1411 1244 1624"> <thead> <tr> <th>Length and Width</th> <th>Acc. Qty</th> </tr> </thead> <tbody> <tr> <td>$c > 3.0, b < 1.0$</td> <td>1</td> </tr> <tr> <td>$c < 3.0, b < 1.0$</td> <td>2</td> </tr> <tr> <td>$c < 3.0, b < 0.5$</td> <td>4</td> </tr> <tr> <td colspan="2">$a < \text{Glass Thickness}$</td> </tr> </tbody> </table>	Length and Width	Acc. Qty	$c > 3.0, b < 1.0$	1	$c < 3.0, b < 1.0$	2	$c < 3.0, b < 0.5$	4	$a < \text{Glass Thickness}$	
Length and Width	Acc. Qty											
$c > 3.0, b < 1.0$	1											
$c < 3.0, b < 1.0$	2											
$c < 3.0, b < 0.5$	4											
$a < \text{Glass Thickness}$												

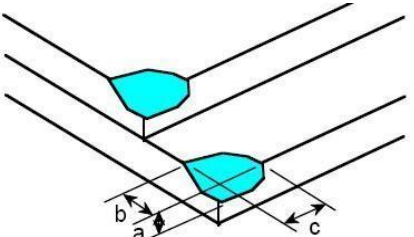
08	Glass Corner Chipping: (Minor defect)	 <table border="1" data-bbox="774 1780 1244 1915"> <thead> <tr> <th>Length and Width</th> <th>Acc. Qty</th> </tr> </thead> <tbody> <tr> <td>$c < 3.0, b < 3.0$</td> <td>Ignore</td> </tr> <tr> <td colspan="2">$a < \text{Glass Thickness}$</td> </tr> </tbody> </table>	Length and Width	Acc. Qty	$c < 3.0, b < 3.0$	Ignore	$a < \text{Glass Thickness}$	
Length and Width	Acc. Qty							
$c < 3.0, b < 3.0$	Ignore							
$a < \text{Glass Thickness}$								

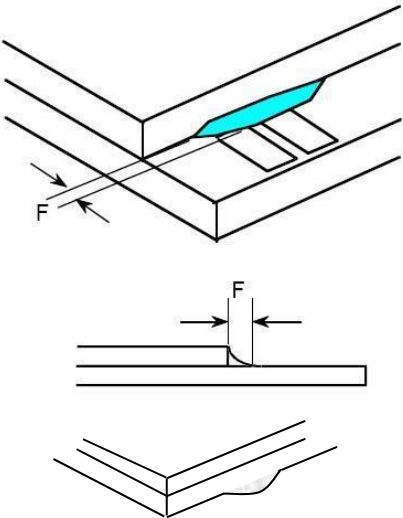
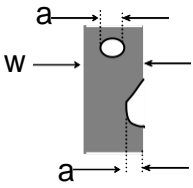

09	<p>Glass Burr: (Minor defect)</p> 	<table border="1" data-bbox="775 232 1246 320"> <thead> <tr> <th>Length</th> <th>Acc. Qty</th> </tr> </thead> <tbody> <tr> <td>$F < 1.0$</td> <td>Ignore</td> </tr> </tbody> </table> <p>Glass burr don't affect assemble and module dimension.</p>	Length	Acc. Qty	$F < 1.0$	Ignore				
Length	Acc. Qty									
$F < 1.0$	Ignore									
10	<p>FPC Defect: (Minor defect)</p> 	<p>10.1 Dent, pinhole width $a < w/3$. (w: circuitry width.)</p> <p>10.2 Open circuit is unacceptable.</p> <p>10.3 No oxidation, contamination and distortion.</p>								
11	<p>Bubble on Polarizer (Minor defect)</p>	<table border="1" data-bbox="651 1200 1121 1373"> <thead> <tr> <th>Diameter</th> <th>Acc. Qty</th> </tr> </thead> <tbody> <tr> <td>$\varphi \leq 0.30$</td> <td>Ignore</td> </tr> <tr> <td>$0.30 < \varphi \leq 0.50$</td> <td>$N \leq 2$</td> </tr> <tr> <td>$0.50 < \varphi$</td> <td>$N = 0$</td> </tr> </tbody> </table>	Diameter	Acc. Qty	$\varphi \leq 0.30$	Ignore	$0.30 < \varphi \leq 0.50$	$N \leq 2$	$0.50 < \varphi$	$N = 0$
Diameter	Acc. Qty									
$\varphi \leq 0.30$	Ignore									
$0.30 < \varphi \leq 0.50$	$N \leq 2$									
$0.50 < \varphi$	$N = 0$									
12	<p>Dent on Polarizer (Minor defect)</p>	<table border="1" data-bbox="651 1442 1121 1615"> <thead> <tr> <th>Diameter</th> <th>Acc. Qty</th> </tr> </thead> <tbody> <tr> <td>$\varphi \leq 0.25$</td> <td>Ignore</td> </tr> <tr> <td>$0.25 < \varphi \leq 0.50$</td> <td>$N \leq 4$</td> </tr> <tr> <td>$0.50 < \varphi$</td> <td>None</td> </tr> </tbody> </table>	Diameter	Acc. Qty	$\varphi \leq 0.25$	Ignore	$0.25 < \varphi \leq 0.50$	$N \leq 4$	$0.50 < \varphi$	None
Diameter	Acc. Qty									
$\varphi \leq 0.25$	Ignore									
$0.25 < \varphi \leq 0.50$	$N \leq 4$									
$0.50 < \varphi$	None									
13	<p>Bezel</p>	<p>13.1 No rust, distortion on the Bezel.</p> <p>13.2 No visible fingerprints, stains or other contamination.</p>								



14	Touch Panel	<p>D: Diameter W: width L: length</p> <p>14.1 Spot: $D < 0.25$ is acceptable $0.25 \leq D \leq 0.4$</p> <p>2dots are acceptable and the distance between defects should more than 10 mm.</p> <p>$D > 0.4$ is unacceptable</p> <p>14.2 Dent: $D > 0.40$ is unacceptable</p> <p>14.3 Scratch: $W \leq 0.03$, $L \leq 10$ is acceptable, $0.03 < W \leq 0.10$, $L \leq 10$ is acceptable</p> <p>Distance between 2 defects should more than 10 mm. $W > 0.10$ is unacceptable.</p>
15	PCB	<p>15.1 No distortion or contamination on PCB terminals.</p> <p>15.2 All components on PCB must same as documented on the BOM/component layout.</p> <p>15.3 Follow IPC-A-600F.</p>
16	Soldering	Follow IPC-A-610C standard
17	Electrical Defect (Major defect)	<p>The below defects must be rejected.</p> <p>17.1 Missing vertical / horizontal segment,</p> <p>17.2 Abnormal Display.</p> <p>17.3 No function or no display.</p> <p>17.4 Current exceeds product specifications.</p> <p>17.5 LCD viewing angle defect.</p> <p>17.6 No Backlight.</p> <p>17.7 Dark Backlight.</p> <p>17.8 Touch Panel no function.</p>

Remark: LCD Panel Broken shall be rejected. Defect out of LCD viewing area is acceptable.

10.7 Classification of Defects

- 10.7.1 Visual defects (Except no / wrong label) are treated as minor defect and electrical defect is major.
- 10.7.2 Two minor defects are equal to one major in lot sampling inspection.

10.8 Identification/marketing criteria

Any unit with illegible / wrong /double or no marking/ label shall be rejected.

10.9 Packing

- 10.9.1 There should be no damage of the outside carton box, each packaging box should have one identical label.
- 10.9.2 Modules inside package box should have compliant mark.
- 10.9.3 All direct package materials shall offer ESD protection

Note1: Bright dot is defined as the defective area of the dot is larger than 50% of one sub-pixel area.

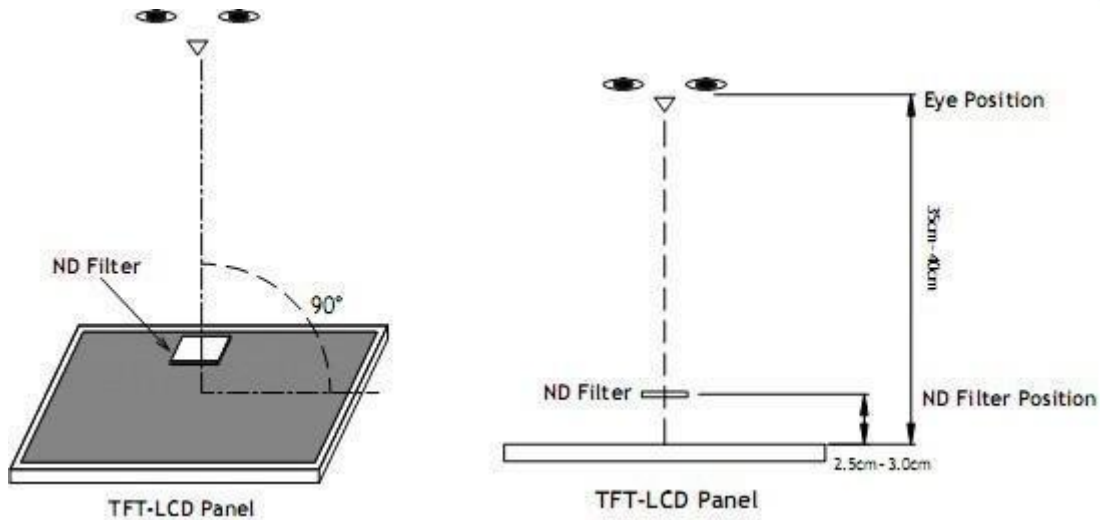

Bright dot: The bright dot size defect at black display pattern. It can be recognized by 2% transparency of filter when the distance between eyes and panel is $350\text{mm} \pm 50\text{mm}$.

Dark dot: cyan, magenta or yellow dot size defect at white display pattern. It can be recognized by 5% transparency of filter when the distance between eyes and panel is $350\text{mm} \pm 50\text{mm}$.

Note2: Mura on display which appears darker/brighter against background brightness on parts of display area.

11. Reliability Specification

No	Item	Condition	Quantity	Criteria
1	High Temperature Operating	70°C, 96Hrs	2	GB/T2423.2-2008
2	Low Temperature Operating	-20°C, 96Hrs	2	GB/T2423.1-2008
3	High Humidity	50°C, 90%RH, 96Hrs	2	GB/T2423.3-2006
4	High Temperature Storage	80°C, 96Hrs	2	GB/T2423.2-2008
5	Low Temperature Storage	-30°C, 96Hrs	2	GB/T2423.1-2008
6	Thermal Cycling Test	-30°C, 60min~80°C, 60min, 20 cycles.	2	GB/T2423.22-2012
7	Packing Vibration	Frequency range:10Hz~50Hz Acceleration of gravity:5G X, Y, Z 30 min for each direction.	2	GB/T5170.14-2009
8	Electrical Static Discharge	Air: $\pm 8\text{KV}$ 150pF/330 Ω 5 times Contact: $\pm 4\text{KV}$ 150pF/330 Ω 5 times	2	GB/T17626.2-2006
9	Drop Test (Packaged)	Height:80 cm, 1 corner, 3 edges, 6 surfaces.	2	GB/T2423.8-1995

Note1. No deflection cosmetic and operational function allowable.

Note2. Total current Consumption should be below double of initial value



12. Precautions and Warranty

12.1. Safety

12.1.1 The liquid crystal in the LCD is poisonous. Do not put it in your mouth. If the liquid crystal touches your skin or clothes, wash it off immediately using soap and water.

12.1.2 Since the liquid crystal cells are made of glass, do not apply strong impact on them. Handle with care.

12.2. Handling

12.2.1 Reverse and use within ratings in order to keep performance and prevent damage.

12.2.2 Do not wipe the polarizer with dry cloth, as it might cause scratch. If the surface of the LCD needs to be cleaned, wipe it swiftly with cotton or other soft cloth soaked with petroleum IPA, do not use other chemicals.

12.3. Storage

12.3.1. Do not store the LCD module beyond the specified temperature ranges.

12.3.2. Strong light exposure causes degradation of polarizer and color filter

12.4. Metal Pin (Apply to Products with Metal Pins)

12.4.1 Pins of LCD and Backlight

12.4.1.1 Solder tip can touch and press on the tip of Pin LEAD during the soldering

12.4.1.2 Recommended Soldering Conditions

Solder Type: Sn96.3~94-Ag3.3~4.3-Cu0.4~1.1

Maximum Solder Temperature: 370°C

Maximum Solder Time: 3s at the maximum temperature

Recommended Soldering Temp: 350±20°C

Typical Soldering Time: ≤3s

12.4.1.3 Solder Wetting

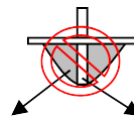
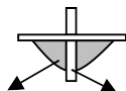

Solder Pin Lead
Recommended

Solder Pin Lead
Not Recommended

12.4.2 Pins of EL

12.4.1.1 Solder tip can touch and press on the tip of EL leads during soldering.

12.4.1.2 No Solder Paste on the soldering pad on the motherboard is recommended.

12.4.1.3 Recommended Soldering Conditions

Solder type: Nippon Alimit Leadfree SR-34, size 0.5mm

Recommended Solder Temperature: 270~290°C

Typical Soldering Time: ≤2s

Minimum solder distance from EL lamp (body):2.0mm

12.4.1.4 No horizontal press on the EL leads during soldering.

12.4.1.5 180° bend EL leads three times is not allowed.



12.4.1.6 Solder Wetting

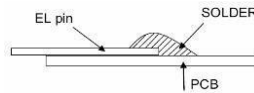

Recommended

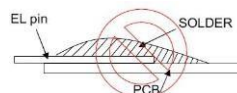

Not Recommended

12.4.1.7 The type of the solder iron:

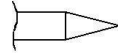

Recommended

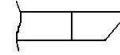

Not Recommended

12.4.1.8 Solder Pad

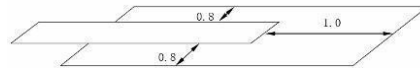

12.5. Operation

- 12.5.1. Do not drive LCD with DC voltage
- 12.5.2. Response time will increase below lower temperature
- 12.5.3. Display may change color with different temperature
- 12.5.4. Mechanical disturbance during operation, such as pressing on the display area, may cause the segments to appear "fractured".
- 12.5.5. Do not connect or disconnect the LCM to or from the system when power is on.
- 12.5.6. Never use the LCM under abnormal condition of high temperature and high humidity.
- 12.5.7. Module has high frequency circuits. Sufficient suppression to the electromagnetic interface shall be done by system manufacturers. Grounding and shielding methods may be important to minimize the interference.
- 12.5.8. Do not display the fixed pattern for long time (we suggest the time not longer than one hour) because it may develop image sticking due to the TFT structure.

12.6. Static Electricity

- 12.6.1. CMOS LSIs are equipped in this unit, so care must be taken to avoid the electro-static charge, by ground human body, etc.
- 12.6.2. The normal static prevention measures should be observed for work clothes and benches.
- 12.6.3. The module should be kept into anti-static bags or other containers resistant to static for storage.

12.7. Limited Warranty

- 12.7.1. Our warranty liability is limited to repair and/or replacement. We will not be responsible for any consequential loss.
- 12.7.2. If possible, we suggest customer to use up all modules in six months. If the module storage time over twelve months, we suggest that recheck it before the module be used
- 12.7.3. After the product shipped, any product quality issues must be feedback within three months, otherwise, we will not be responsible for the subsequent or consequential events.

