



AGTechnologies

SPECIFICATION

AGM 240128W-601

Atualizado pelo MKT em 06/01/2016



RECORDS OF REVISION

DOC. FIRST ISSUE

VERSION	DATE	REVISED PAGE NO.	SUMMARY
0	2010/07/09		First issue
A	2011/03/14		Correct VLCD Description
B	2011/09/21		Correct PIN Description.
C	2011/10/31		Correct Absolute Maximum Ratings.
D	2011/11/07		Correct VLCD.
E	2012/02/16		Correct pin Description
F	2012/08/15		Modify backlight information.
G	2014/07/04		Remove IC information Modify B/L information
H	2015/02/04		Add Pull Tape

Contents

- 1.Precautions in use of LCD Modules
- 2.General Specification
- 3.Absolute Maximum Ratings
- 4.Electrical Characteristics
- 5.Optical Characteristics
- 6.Interface Pin Function
- 7.Contour Drawing
- 8.Reliability
- 9.Backlight Information
- 10.Inspection specification
- 11.Material List of Components for RoHs
- 12.Recommendable Storage

1.Precautions in use of LCD Modules

- (1) Avoid applying excessive shocks to the module or making any alterations or modifications to it.
- (2) Don't make extra holes on the printed circuit board, modify its shape or change the components of LCD module.
- (3) Don't disassemble the LCM.
- (4) Don't operate it above the absolute maximum rating.
- (5) Don't drop, bend or twist LCM.
- (6) Soldering: only to the I/O terminals.
- (7) Storage: please storage in anti-static electricity container and clean environment.
- (8) AGT have the right to change the passive components, including R3,R6 & backlight adjust resistors. (Resistors, capacitors and other passive components will have different appearance and color caused by the different supplier.)
- (9) AGT have the right to change the PCB Rev. (In order to satisfy the supplying stability, management optimization and the best product performance...etc, under the premise of not affecting the electrical characteristics and external dimensions, AGT have the right to modify the version.)

2.General Specification

Item	Dimension	Unit
Number of Characters	240 x 128 dots	—
Module dimension	98.7 x 67.7 x 9.5	mm
View area	92.0 x 53.0	mm
Active area	83.975 x 44.775	mm
Dot size	0.325 x 0.325	mm
Dot pitch	0.35 x 0.35	mm
LCD type	FSTN Positive Transflective (In LCD production, It will occur slightly color difference. We can only guarantee the same color in the same batch.)	
Duty	1/128 , 1/12 Bias	
View direction	6 o'clock	
Backlight Type	LED, White	
IC	UC1608	

3. Absolute Maximum Ratings

Item	Symbol	Min	Typ	Max	Unit
Operating Temperature	T_{OP}	-20	—	+70	°C
Storage Temperature	T_{ST}	-30	—	+80	°C
Logic supply voltage	V_{DD}	-0.3	—	+4.0	V
LCD Generator supply voltage	V_{DD2}	-0.3	—	+4.0	V
LCD Generated voltage	V_{LCD}	-0.3	—	+17.0	V

4. Electrical Characteristics

Item	Symbol	Condition	Min	Typ	Max	Unit
Supply Voltage For Logic	$V_{DD}-V_{SS}$	—	2.7	2.8~3.3	3.6	V
Supply Voltage For LCM	V_{LCD}	$T_a=-20^{\circ}C$	—	—	—	V
		$T_a=25^{\circ}C$	15.2	15.5	15.8	V
		$T_a=70^{\circ}C$	—	—	—	V
Input High Volt.	V_{IH}	—	$0.8 V_{DD}$	—	—	V
Input Low Volt.	V_{IL}	—	—	—	$0.2 V_{DD}$	V
Output High Volt.	V_{OH}	—	$0.8 V_{DD}$	—	—	V
Output Low Volt.	V_{OL}	—	—	—	$0.2 V_{DD}$	V
Supply Current(No include LED Backlight)	I_{DD}	$V_{DD}=3.0V$	—	1.1	—	mA

Please kindly consider to design the V_{op} to be adjustable while programing the software to match LCD contrast tolerance.

5. Optical Characteristics

Item	Symbol	Condition	Min	Typ	Max	Unit
View Angle	θ	$CR \geq 2$	0	—	30	$\psi = 180^\circ$
	θ	$CR \geq 2$	0	—	60	$\psi = 0^\circ$
	θ	$CR \geq 2$	0	—	45	$\psi = 90^\circ$
	θ	$CR \geq 2$	0	—	45	$\psi = 270^\circ$
Contrast Ratio	CR	—	—	5	—	—
Response Time	T rise	—	—	200	300	ms
	T fall	—	—	250	350	ms

Definition of Operation Voltage (Vop)

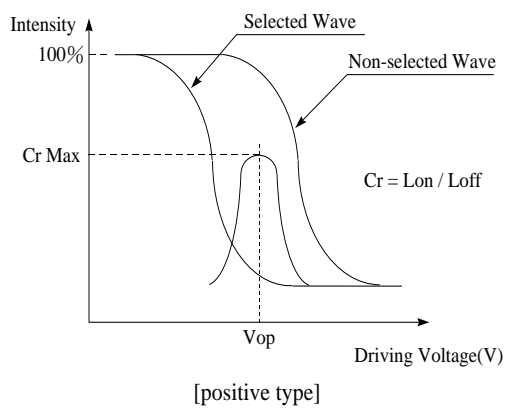

Definition of Response Time (Tr, Tf)

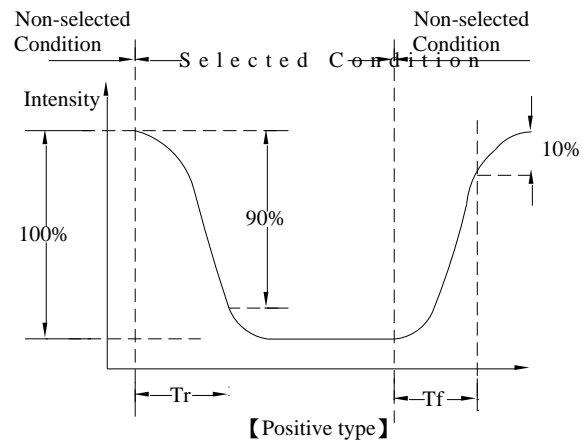

Conditions :

Operating Voltage : Vop

Viewing Angle(θ , φ) : 0° , 0°

Frame Frequency : 64 HZ

Driving Waveform : 1/N duty , 1/a bias

Definition of viewing angle($CR \geq 2$)

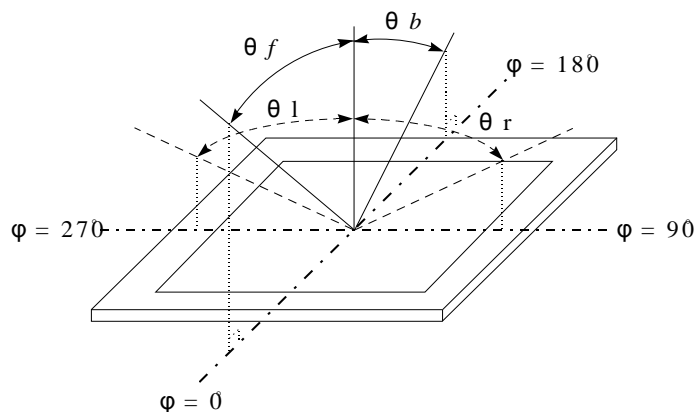

6. Interface Pin Function

Pin No.	Symbol	Type	Description
1	VB1-	PWR	LCD Bias Voltages. These are the voltage source to provide SEG driving currents. These voltages are generated internally. Connect capacitors of CBX between VBX+ and VBX-. The resistance of these four traces directly affects the SEG driving strength of the resulting LCD module. Minimize the trace resistance is critical in achieving high quality image.
2	VB1+		
3	VB0-		
4	VB0+		
5	VLCD	PWR	Main LCD Power Supply. Connect these pins together.
6	VBIAS	I	This is the reference voltage to generate the actual SEG driving voltage. VBIAS can be used to fine tune VLCD by external variable resistors. Internal resistor network has been provided to simplify external trimming circuit. In COF application, connect a small bypass capacitor between VBIAS and VSS to reduce noise.
7	VSS	PWR	Ground
8	VDD	PWR	Supply Voltage for logic
9	D7	I/O	Bi-directional bus for both serial and parallel host interfaces. In serial modes, connect D[0] to SCK, D[3] to SDA,
10	D6		
11	D5		
12	D4		
13	D3		
14	D2		
15	D1		
16	D0		
17	WR1	I	WR[1:0] controls the read/write operation of the host interface. See Host Interface section for more detail. In parallel mode, WR[1:0] meaning depends on whether the interface is in the 6800 mode or the 8080 mode. In serial interface modes, these two pins are not used, connect them to VSS.
18	WR0		
19	CD	I	Select Control data or Display data for read/write operation. In S9 mode, CD pin is not used. Connect CD to VSS when not used. "L": Control data "H": Display data

	BM=1x (Parallel)	BM=0x (Parallel)	BM=01 (S9)	BM=00 (S8/S8uc)
D0	D0	D0/D4	SCK	SCK
D1	D1	D1/D5	-	-
D2	D2	D2/D6	-	-
D3	D3	D3/D7	SDA	SDA
D4	D4	-	-	-
D5	D5	-	-	-
D6	D6	-	S9	S8/S8uc
D7	D7	0	1	1

20	RST	I	<p>When RST="L", all control registers are re-initialized by their default states.</p> <p>Since UC1608x has built-in Power-ON-Reset and Software Reset command, RST pin is not required for proper chip operation. When RST is not used, connect the pin to VDD.</p>																								
21	CS	I	<p>Chip Select. The chip is selected when CS="H". When the chip is not selected, D[7:0] will be high impedance.</p>																								
22	BM0	I	<p>Bus mode: The interface bus mode is determined by BM[1:0] and D[7:6] by the following relationship:</p> <table border="1" data-bbox="592 584 1334 965"> <thead> <tr> <th>BM[1:0]</th> <th>D[7:6]</th> <th>Mode</th> </tr> </thead> <tbody> <tr> <td>11</td> <td>Data</td> <td>6800/8-bit</td> </tr> <tr> <td>10</td> <td>Data</td> <td>8080/8-bit</td> </tr> <tr> <td>01</td> <td>0X</td> <td>6800/4-bit</td> </tr> <tr> <td>00</td> <td>0X</td> <td>8080/4-bit</td> </tr> <tr> <td>01</td> <td>10</td> <td>3-wire SPI w/ 9-bit token (S9: conventional)</td> </tr> <tr> <td>00</td> <td>10</td> <td>4-wire SPI w/ 8-bit token (S8: conventional)</td> </tr> <tr> <td>00</td> <td>11</td> <td>3- or 4-wire SPI w/ 8-bit token (S8uc: Ultra-Compact)</td> </tr> </tbody> </table>	BM[1:0]	D[7:6]	Mode	11	Data	6800/8-bit	10	Data	8080/8-bit	01	0X	6800/4-bit	00	0X	8080/4-bit	01	10	3-wire SPI w/ 9-bit token (S9: conventional)	00	10	4-wire SPI w/ 8-bit token (S8: conventional)	00	11	3- or 4-wire SPI w/ 8-bit token (S8uc: Ultra-Compact)
BM[1:0]	D[7:6]		Mode																								
11	Data	6800/8-bit																									
10	Data	8080/8-bit																									
01	0X	6800/4-bit																									
00	0X	8080/4-bit																									
01	10	3-wire SPI w/ 9-bit token (S9: conventional)																									
00	10	4-wire SPI w/ 8-bit token (S8: conventional)																									
00	11	3- or 4-wire SPI w/ 8-bit token (S8uc: Ultra-Compact)																									
23	BM1																										

7. Contour Drawing

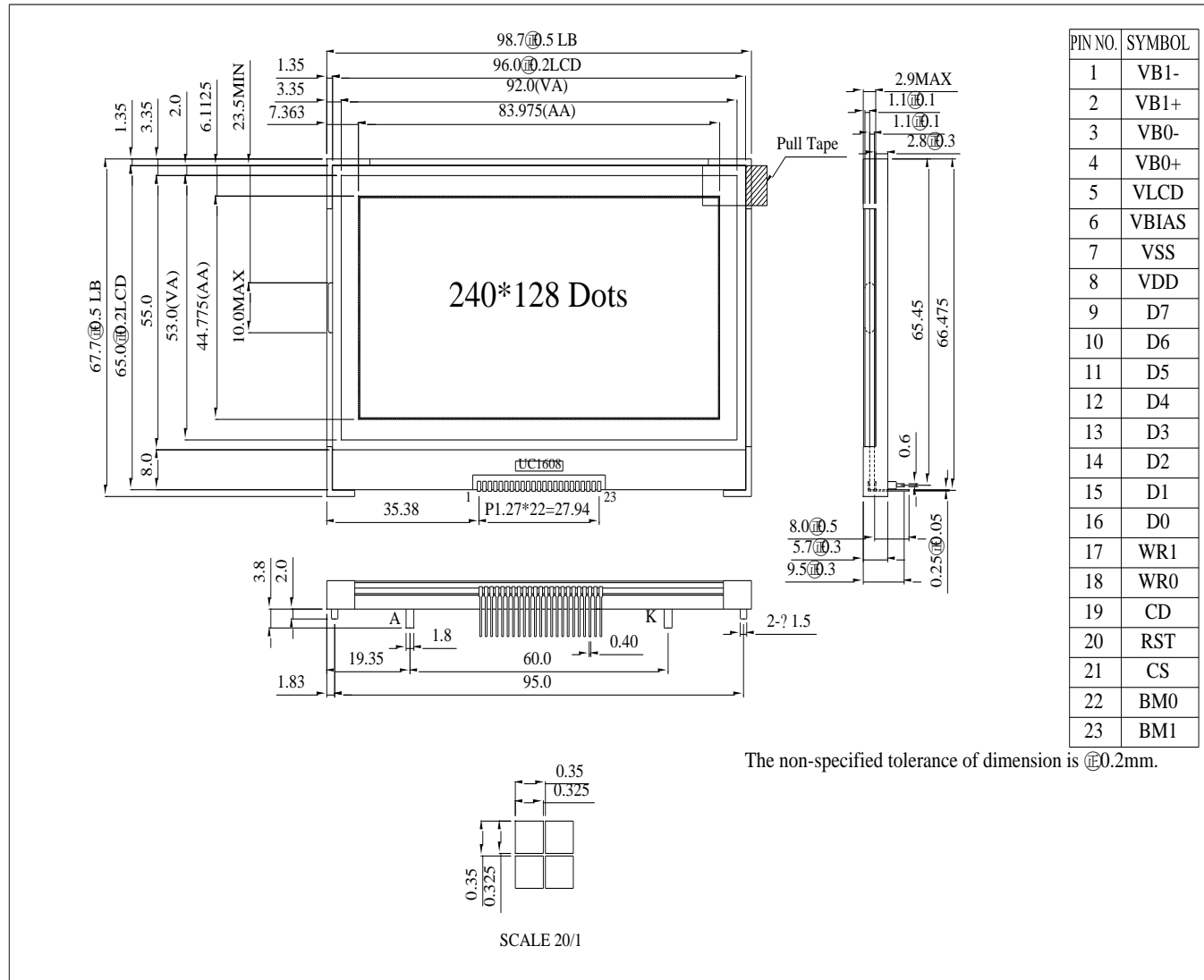

8. Reliability

Content of Reliability Test (Wide temperature, -20°C~70°C)

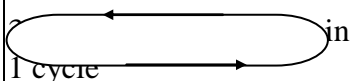
Environmental Test			
Test Item	Content of Test	Test Condition	Note
High Temperature storage	Endurance test applying the high storage temperature for a long time.	80°C 200hrs	2
Low Temperature storage	Endurance test applying the low storage temperature for a long time.	-30°C 200hrs	1,2
High Temperature Operation	Endurance test applying the electric stress (Voltage & Current) and the thermal stress to the element for a long time.	70°C 200hrs	—
Low Temperature Operation	Endurance test applying the electric stress under low temperature for a long time.	-20°C 200hrs	1
High Temperature/ Humidity storage	The module should be allowed to stand at 60°C, 90%RH max For 96hrs under no-load condition excluding the polarizer, Then taking it out and drying it at normal temperature.	60°C, 90%RH 96hrs	1,2
Thermal shock resistance	The sample should be allowed stand the following 10 cycles of operation -20°C 25°C 70°C 	-20°C / 70°C 10 cycles	—
Vibration test	Endurance test applying the vibration during transportation and using.	Total fixed amplitude : 1.5mm Vibration Frequency : 10~55Hz One cycle 60 seconds to 3 directions of X,Y,Z for Each 15 minutes	3
Static electricity test	Endurance test applying the electric stress to the terminal.	VS=800V, RS=1.5kΩ CS=100pF 1 time	—

Note1: No dew condensation to be observed.

Note2: The function test shall be conducted after 4 hours storage at the normal Temperature and humidity after remove from the test chamber.

Note3: The packing have to including into the vibration testing.

9. Backlight Information

Specification

PARAMETER	SYMBOL	MIN	TYP	MAX	UNIT	TEST CONDITION
Supply Current	I _{LED}	86.4	96	120	mA	V=3.5V
Supply Voltage	V	3.3	3.5	3.7	V	
Reverse Voltage	V _R	—	—	5	V	—
Luminance (Without LCD)	I _V	400	500	—	CD/M2	I _{LED} =96mA
Wave Length	X	0.28	0.3	0.32		I _{LED} =96mA
	Y	0.28	0.3	0.32		
LED Life Time (For Reference only)	—	—	100K	—	Hr.	I _{LED} ≤ 96mA 25°C, 50-60%RH, (Note 1)
Color	White					

Note: The LED of B/L is drive by current only ; driving voltage is only for reference
To make driving current in safety area (waste current between minimum and maximum).

Note 1: 50K hours is only an estimate for reference.

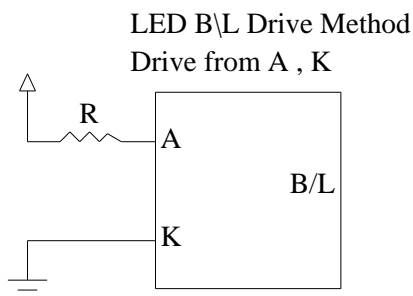

10. Inspection specification

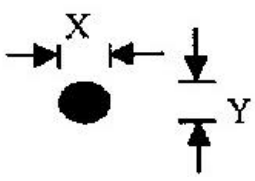
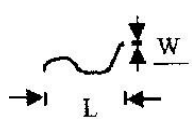
NO	Item	Criterion	AQL												
01	Electrical Testing	<p>Missing vertical, horizontal segment, segment contrast defect.</p> <p>Missing character , dot or icon.</p> <p>Display malfunction.</p> <p>No function or no display.</p> <p>Current consumption exceeds product specifications.</p> <p>LCD viewing angle defect.</p> <p>Mixed product types.</p> <p>Contrast defect.</p>	0.65												
02	Black or white spots on LCD (display only)	<p>2.1 White and black spots on display $\leq 0.25\text{mm}$, no more than three white or black spots present.</p> <p>2.2 Densely spaced: No more than two spots or lines within 3mm</p>	2.5												
03	LCD black spots, white spots, contamination (non-display)	<p>3.1 Round type : As following drawing</p> <p>$\Phi = (x + y) / 2$</p>  <table border="1" data-bbox="805 981 1332 1236"> <thead> <tr> <th>SIZE</th> <th>Acceptable Q TY</th> </tr> </thead> <tbody> <tr> <td>$\Phi \leq 0.10$</td> <td>Accept no dense</td> </tr> <tr> <td>$0.10 < \Phi \leq 0.20$</td> <td>2</td> </tr> <tr> <td>$0.20 < \Phi \leq 0.25$</td> <td>1</td> </tr> <tr> <td>$0.25 < \Phi$</td> <td>0</td> </tr> </tbody> </table>	SIZE	Acceptable Q TY	$\Phi \leq 0.10$	Accept no dense	$0.10 < \Phi \leq 0.20$	2	$0.20 < \Phi \leq 0.25$	1	$0.25 < \Phi$	0	2.5		
		SIZE	Acceptable Q TY												
$\Phi \leq 0.10$	Accept no dense														
$0.10 < \Phi \leq 0.20$	2														
$0.20 < \Phi \leq 0.25$	1														
$0.25 < \Phi$	0														
<p>3.2 Line type : (As following drawing)</p>  <table border="1" data-bbox="694 1328 1332 1579"> <thead> <tr> <th>Length</th> <th>Width</th> <th>Acceptable Q TY</th> </tr> </thead> <tbody> <tr> <td>---</td> <td>$W \leq 0.02$</td> <td>Accept no dense</td> </tr> <tr> <td>$L \leq 3.0$</td> <td>$0.02 < W \leq 0.03$</td> <td rowspan="2">2</td> </tr> <tr> <td>$L \leq 2.5$</td> <td>$0.03 < W \leq 0.05$</td> </tr> <tr> <td>---</td> <td>$0.05 < W$</td> <td>As round type</td> </tr> </tbody> </table>	Length	Width	Acceptable Q TY	---	$W \leq 0.02$	Accept no dense	$L \leq 3.0$	$0.02 < W \leq 0.03$	2	$L \leq 2.5$	$0.03 < W \leq 0.05$	---	$0.05 < W$	As round type	2.5
Length	Width	Acceptable Q TY													
---	$W \leq 0.02$	Accept no dense													
$L \leq 3.0$	$0.02 < W \leq 0.03$	2													
$L \leq 2.5$	$0.03 < W \leq 0.05$														
---	$0.05 < W$	As round type													
04	Polarizer bubbles	<p>If bubbles are visible, judge using black spot specifications, not easy to find, must check in specify direction.</p> <table border="1" data-bbox="826 1706 1332 2004"> <thead> <tr> <th>Size Φ</th> <th>Acceptable Q TY</th> </tr> </thead> <tbody> <tr> <td>$\Phi \leq 0.20$</td> <td>Accept no dense</td> </tr> <tr> <td>$0.20 < \Phi \leq 0.50$</td> <td>3</td> </tr> <tr> <td>$0.50 < \Phi \leq 1.00$</td> <td>2</td> </tr> <tr> <td>$1.00 < \Phi$</td> <td>0</td> </tr> <tr> <td>Total Q TY</td> <td>3</td> </tr> </tbody> </table>	Size Φ	Acceptable Q TY	$\Phi \leq 0.20$	Accept no dense	$0.20 < \Phi \leq 0.50$	3	$0.50 < \Phi \leq 1.00$	2	$1.00 < \Phi$	0	Total Q TY	3	2.5
Size Φ	Acceptable Q TY														
$\Phi \leq 0.20$	Accept no dense														
$0.20 < \Phi \leq 0.50$	3														
$0.50 < \Phi \leq 1.00$	2														
$1.00 < \Phi$	0														
Total Q TY	3														

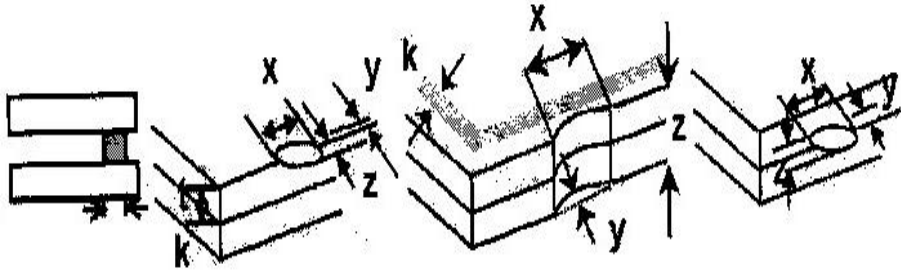
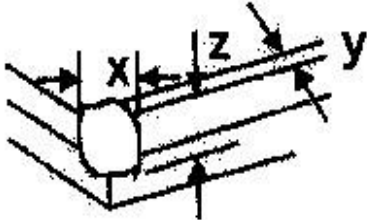
NO	Item	Criterion	AQL																		
05	Scratches	Follow NO.3 LCD black spots, white spots, contamination																			
06	Chipped glass	<p>Symbols Define: x: Chip length y: Chip width z: Chip thickness k: Seal width t: Glass thickness a: LCD side length L: Electrode pad length:</p> <p>6.1 General glass chip : 6.1.1 Chip on panel surface and crack between panels:</p>  <table border="1" data-bbox="443 929 1353 1140"> <tr> <td>z: Chip thickness</td> <td>y: Chip width</td> <td>x: Chip length</td> </tr> <tr> <td>$Z \leq 1/2t$</td> <td>Not over viewing area</td> <td>$x \leq 1/8a$</td> </tr> <tr> <td>$1/2t < z \leq 2t$</td> <td>Not exceed 1/3k</td> <td>$x \leq 1/8a$</td> </tr> </table> <p>⊙If there are 2 or more chips, x is total length of each chip.</p> <p>6.1.2 Corner crack:</p>  <table border="1" data-bbox="443 1570 1353 1780"> <tr> <td>z: Chip thickness</td> <td>y: Chip width</td> <td>x: Chip length</td> </tr> <tr> <td>$Z \leq 1/2t$</td> <td>Not over viewing area</td> <td>$x \leq 1/8a$</td> </tr> <tr> <td>$1/2t < z \leq 2t$</td> <td>Not exceed 1/3k</td> <td>$x \leq 1/8a$</td> </tr> </table> <p>⊙If there are 2 or more chips, x is the total length of each chip.</p>	z: Chip thickness	y: Chip width	x: Chip length	$Z \leq 1/2t$	Not over viewing area	$x \leq 1/8a$	$1/2t < z \leq 2t$	Not exceed 1/3k	$x \leq 1/8a$	z: Chip thickness	y: Chip width	x: Chip length	$Z \leq 1/2t$	Not over viewing area	$x \leq 1/8a$	$1/2t < z \leq 2t$	Not exceed 1/3k	$x \leq 1/8a$	2.5
z: Chip thickness	y: Chip width	x: Chip length																			
$Z \leq 1/2t$	Not over viewing area	$x \leq 1/8a$																			
$1/2t < z \leq 2t$	Not exceed 1/3k	$x \leq 1/8a$																			
z: Chip thickness	y: Chip width	x: Chip length																			
$Z \leq 1/2t$	Not over viewing area	$x \leq 1/8a$																			
$1/2t < z \leq 2t$	Not exceed 1/3k	$x \leq 1/8a$																			

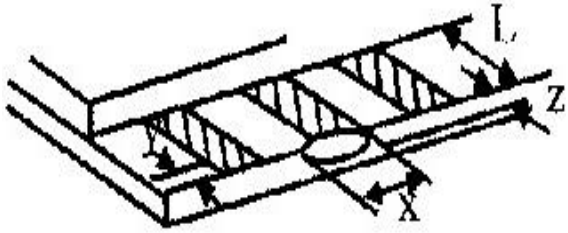
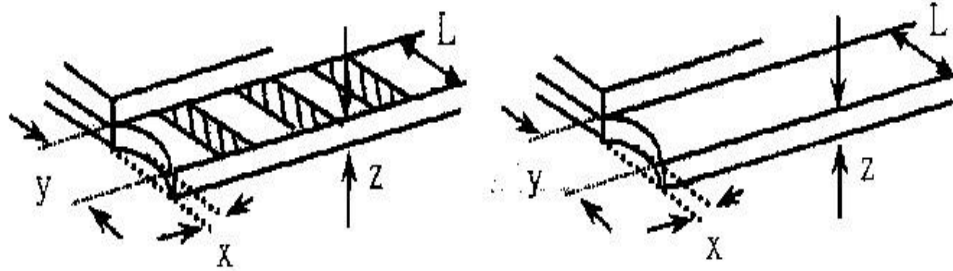
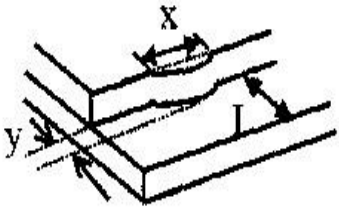
NO	Item	Criterion	AQL																
06	Glass crack	<p>Symbols :</p> <p>x: Chip length y: Chip width z: Chip thickness</p> <p>k: Seal width t: Glass thickness a: LCD side length</p> <p>L: Electrode pad length</p> <p>6.2 Protrusion over terminal :</p> <p>6.2.1 Chip on electrode pad :</p>  <table border="1" data-bbox="352 808 1273 909"> <tr> <td>y: Chip width</td> <td>x: Chip length</td> <td>z: Chip thickness</td> </tr> <tr> <td>$y \leq 0.5\text{mm}$</td> <td>$x \leq 1/8a$</td> <td>$0 < z \leq t$</td> </tr> </table> <p>6.2.2 Non-conductive portion:</p>  <table border="1" data-bbox="424 1290 1251 1406"> <tr> <td>y: Chip width</td> <td>x: Chip length</td> <td>z: Chip thickness</td> </tr> <tr> <td>$y \leq L$</td> <td>$x \leq 1/8a$</td> <td>$0 < z \leq t$</td> </tr> </table> <p>⊙ If the chipped area touches the ITO terminal, over 2/3 of the ITO must remain and be inspected according to electrode terminal specifications.</p> <p>⊙ If the product will be heat sealed by the customer, the alignment mark not be damaged.</p> <p>6.2.3 Substrate protuberance and internal crack.</p>  <table border="1" data-bbox="762 1664 1321 1765"> <tr> <td>y: width</td> <td>x: length</td> </tr> <tr> <td>$y \leq 1/3L$</td> <td>$x \leq a$</td> </tr> </table>	y: Chip width	x: Chip length	z: Chip thickness	$y \leq 0.5\text{mm}$	$x \leq 1/8a$	$0 < z \leq t$	y: Chip width	x: Chip length	z: Chip thickness	$y \leq L$	$x \leq 1/8a$	$0 < z \leq t$	y: width	x: length	$y \leq 1/3L$	$x \leq a$	2.5
y: Chip width	x: Chip length	z: Chip thickness																	
$y \leq 0.5\text{mm}$	$x \leq 1/8a$	$0 < z \leq t$																	
y: Chip width	x: Chip length	z: Chip thickness																	
$y \leq L$	$x \leq 1/8a$	$0 < z \leq t$																	
y: width	x: length																		
$y \leq 1/3L$	$x \leq a$																		

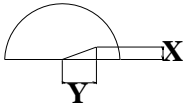
NO	Item	Criterion	AQL
07	Cracked glass	The LCD with extensive crack is not acceptable.	2.5
08	Backlight elements	8.1 Illumination source flickers when lit. 8.2 Spots or scratched that appear when lit must be judged. Using LCD spot, lines and contamination standards. 8.3 Backlight doesn't light or color wrong.	0.65 2.5 0.65
09	Bezel	9.1 Bezel may not have rust, be deformed or have fingerprints, stains or other contamination. 9.2 Bezel must comply with job specifications.	2.5 0.65
10	PCB 、 COB	10.1 COB seal may not have pinholes larger than 0.2mm or contamination. 10.2 COB seal surface may not have pinholes through to the IC. 10.3 The height of the COB should not exceed the height indicated in the assembly diagram. 10.4 There may not be more than 2mm of sealant outside the seal area on the PCB. And there should be no more than three places. 10.5 No oxidation or contamination PCB terminals. 10.6 Parts on PCB must be the same as on the production characteristic chart. There should be no wrong parts, missing parts or excess parts. 10.7 The jumper on the PCB should conform to the product characteristic chart. 10.8 If solder gets on bezel tab pads, LED pad, zebra pad or screw hold pad, make sure it is smoothed down. 10.9 The Scraping testing standard for Copper Coating of PCB  $X * Y \leq 2\text{mm}^2$	2.5 2.5 0.65 2.5 2.5 0.65 2.5 2.5 2.5
11	Soldering	11.1 No un-melted solder paste may be present on the PCB. 11.2 No cold solder joints, missing solder connections, oxidation or icicle. 11.3 No residue or solder balls on PCB. 11.4 No short circuits in components on PCB.	2.5 2.5 2.5 0.65

NO	Item	Criterion	AQL
12	General appearance	12.1 No oxidation, contamination, curves or, bends on interface Pin (OLB) of TCP.	2.5
		12.2 No cracks on interface pin (OLB) of TCP.	0.65
		12.3 No contamination, solder residue or solder balls on product.	2.5
		12.4 The IC on the TCP may not be damaged, circuits.	2.5
		12.5 The uppermost edge of the protective strip on the interface pin must be present or look as if it cause the interface pin to sever.	2.5
		12.6 The residual rosin or tin oil of soldering (component or chip component) is not burned into brown or black color.	2.5
		12.7 Sealant on top of the ITO circuit has not hardened.	2.5
		12.8 Pin type must match type in specification sheet.	0.65
		12.9 LCD pin loose or missing pins.	0.65
		12.10 Product packaging must the same as specified on packaging specification sheet.	0.65
		12.11 Product dimension and structure must conform to product specification sheet.	0.65
		12.12 Visual defect outside of VA is not considered to be rejection.	0.65

11. Material List of Components for RoHs

1. AGTECHNOLOGIES hereby declares that all of or part of products (with the mark “#”in code), including, but not limited to, the LCM, accessories or packages, manufactured and/or delivered to your company (including your subsidiaries and affiliated company) directly or indirectly by our company (including our subsidiaries or affiliated companies) do not intentionally contain any of the substances listed in all applicable EU directives and regulations, including the following substances.

Exhibit A : The Harmful Material List

Material	(Cd)	(Pb)	(Hg)	(Cr6+)	PBBs	PBDEs
Limited Value	100 ppm	1000 ppm	1000 ppm	1000 ppm	1000 ppm	1000 ppm
Above limited value is set up according to RoHS.						

2.Process for RoHS requirement :

- (1) Use the Sn/Ag/Cu soldering surface ; the surface of Pb-free solder is rougher than we used before.
- (2) Heat-resistance temp. :
 - Reflow : 250°C,30 seconds Max. ;
 - Connector soldering wave or hand soldering : 320°C, 10 seconds max.
- (3) Temp. curve of reflow, max. Temp. : 235±5°C ;
 - Recommended customer’s soldering temp. of connector : 280°C, 3 seconds.

12.Recommendable Storage

- 1. Place the panel or module in the temperature 25°C±5°C and the humidity below 65% RH
- 2. Do not place the module near organics solvents or corrosive gases.
- 3. Do not crush, shake, or jolt the module.