



**SPECIFICATION
FOR
LCM MODULE**

AGM 1602F-212

DOCUMENT REVISION HISTORY

Version	DATE	DESCRIPTION	CHANGED BY
00	Mar-18-2009	First issue	
01	Sep-09-2014	Update	

CONTENTS

1. FUNCTIONS & FEATURES.....	1
2. MECHANICAL SPECIFICATIONS.....	1
3. BLOCK DIAGRAM.....	1
4. DIMENSIONAL OUTLINE.....	2
5. PIN DESCRIPTION.....	3
6. MAXIMUM ABSOLUTE LIMIT.....	3
7. ELECTRICAL CHARACTERISTICS.....	4
8. BACKLIGHT CHARACTERISTICS.....	6
10. CONTROL AND DISPLAY INSTRUCTION.....	8
11. FONT CHARACTERISTIC.....	9
12. PRECAUTION FOR USING LCD/LCM.....	10
13. LCM TEST CRITERIA(A1 LEVEL).....	12

1. FUNCTIONS & FEATURES

- 1.1. Format : 16x2characters
- 1.2. LCD mode : STN/Positive/Transflective/YG
- 1.3. Viewing direction : 12'clock
- 1.4. Driving scheme : 1/16 Duty , 1/5 Bias
- 1.5. Power supply voltage (V_{DD}) : 5.0V
- 1.6. LCD driving voltage : 4.5V(reference voltage)
- 1.7. Operation temp : -20~70°C
- 1.8. Storage temp : -30~80°C
- 1.9. Backlight color : Bottom , Yellow-green
- 1.10 RoHS standard

2. MECHANICAL SPECIFICATIONS

- 2.1. Module size : 80.0mm(L)*36.0mm(W)*9.8mm (H) max
- 2.2. Viewing area : 64.0 mm(L)*16.0mm(W)
- 2.3. Character pitch : 3.55mm(L)*5.94mm(W)
- 2.4. Character size : 2.96mm(L)*5.56mm(W)
- 2.5. Dot pitch : 0.60mm(L)*0.70mm(W)
- 2.6. Dot size : 0.56mm(L)*0.66mm(W)
- 2.7. Weight : Approx.

3. BLOCK DIAGRAM

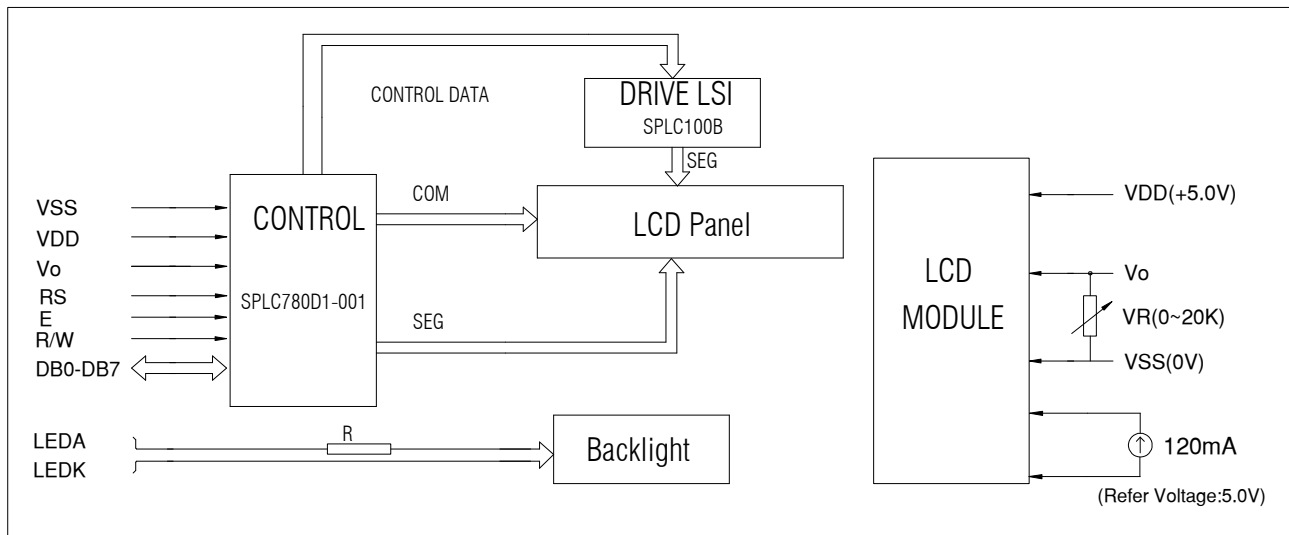

Figure 1. Block diagram

4. DIMENSIONAL OUTLINE

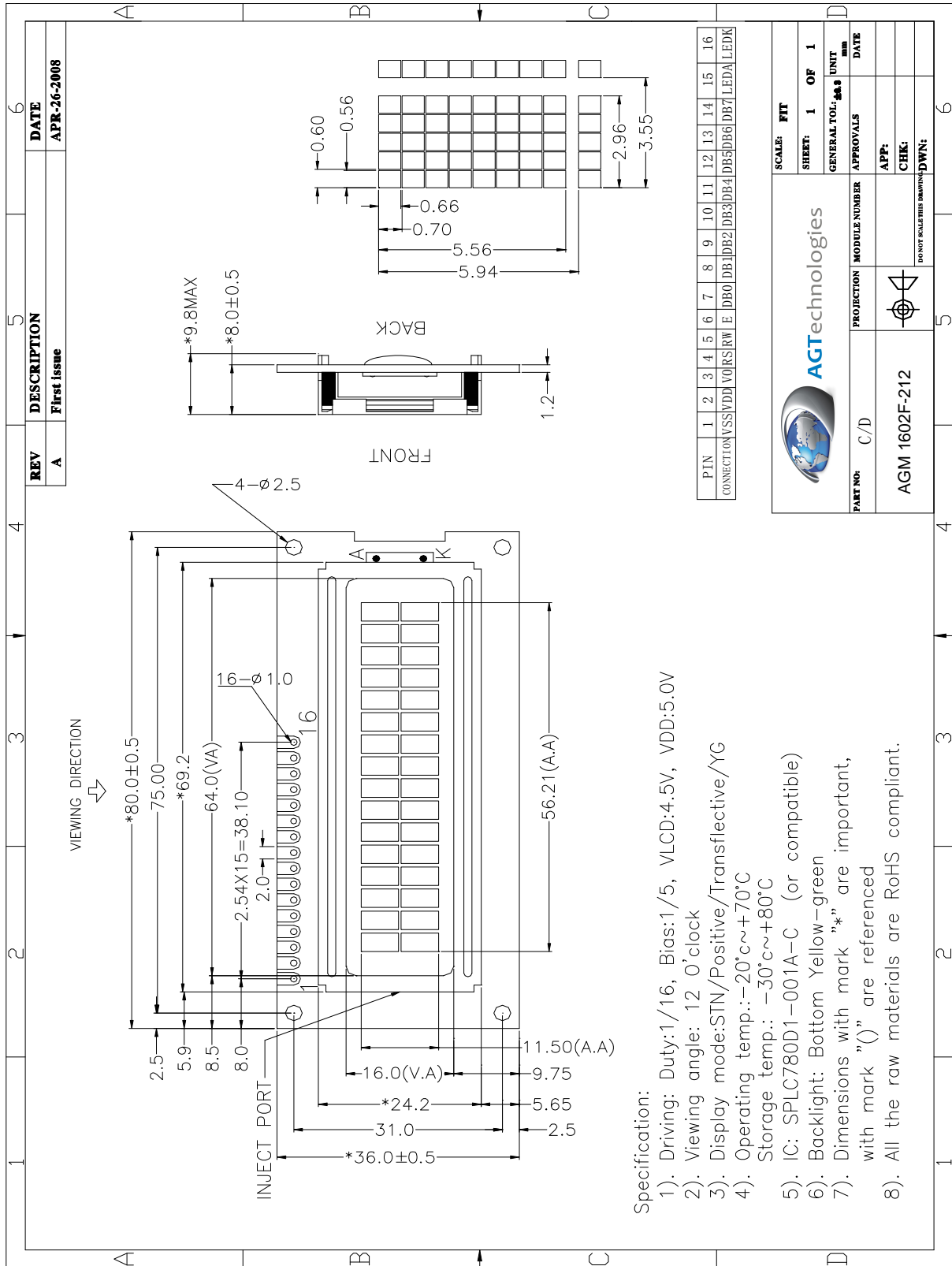

Figure 2. Dimensional outline

5. PIN DESCRIPTION

No.	Symbol	Function
1	VSS	Power ground (0V)
2	VDD	Power supply for Logic(+5V)
3	V0	Power supply for LCD drive
4	RS	Register selection (H: Data register , L :Instruction register)
5	R/W	Read/write selection (H: Read , L: Write)
6	E	Enable signal.
7~14	DB0~DB7	Data Bus line
15	LEDA	Power supply for Backlight(Current 120mA,reference voltage +5V)
16	LEDK	Power supply for Backlight(0V)

6. MAXIMUM ABSOLUTE LIMIT

Item	Symbol	MIN	MAX	Unit
Supply Voltage for Logic	V _{DD}	-0.3	7.0	V
Supply Voltage for LCD	V ₀	V _{DD} -10.0	V _{DD} +0.3	V
Input Voltage	V _{in}	-0.3	V _{DD} +0.3	V
Supply Current for Backlight	I _F (Ta = 25°C)	---	144	mA
Reverse Voltage for Backlight	V _R (Ta = 25°C)	---	10.0	V
Operating Temperature	T _{op}	-20	70	°C
Storage Temperature	T _{st}	-30	80	°C

7. ELECTRICAL CHARACTERISTICS

7.1 DC characteristics (VDD=4.5V-5.5V,TA=25°C)

Characteristics	Symbol	Limit			Unit	Test Condition
		Min.	Typ.	Max.		
Operating Current	I _{DD}	-	0.55	0.8	mA	External clock (Note)
Input High Voltage	V _{IH1}	2.5	-	VDD	V	Pins:(E, RS, R/W, DB0 - DB7)
Input Low Voltage	V _{IL1}	-0.3	-	0.6	V	VDD=5V
Input High Voltage	V _{IH2}	VDD-1	-	VDD	V	Pin OSC1
Input Low Voltage	V _{IL2}	-0.2	-	1.0	V	Pin OSC1
Input High Current	I _{IH}	-2.0	-	2.0	μA	Pins: (RS, R/W, DB0 - DB7)
Input Low Current	I _{IL}	-20	-125	-250	μA	VDD = 5.0V
Output High Voltage (TTL)	V _{OH1}	2.4	-	VDD	V	I _{OH} = - 0.1mA Pins: DB0 - DB7
Output Low Voltage (TTL)	V _{OL1}	-	-	0.4	V	I _{OL} = 0.1mA Pins: DB0 - DB7
Output High Voltage (CMOS)	V _{OH2}	0.9VDD	-	VDD	V	I _{OH} = - 40μA, Pins: CL1, CL2, M, D
Output Low Voltage (CMOS)	V _{OL2}	-	-	0.1VDD	V	I _{OL} = 40μA, Pins: CL1, CL2, M, D
Driver ON Resistance (COM)	R _{COM}	-	-	20	KΩ	I _o = ±50μA, V _{LCD} = 4.0V Pins: COM1 - COM16
Driver ON Resistance (SEG)	R _{SEG}	-	-	30	KΩ	I _o = ±50μA, V _{LCD} = 4.0V Pins: SEG1 - SEG40
LCD Voltage	V _{LCD}	3.0	-	8	V	VDD-V5, 1/4 bias or 1/5 bias

Note: F_{OSC} = 250KHz, VDD = 5.0V, pin E = "L", RS, R/W, DB0 - DB7 are open, all outputs are no loads.

7.2 AC characteristics(VDD=4.5V-5.5V,TA=25°C)

Write mode (writing data from MPU to SPLC780D)

Characteristics	Symbol	Limit			Unit	Test Condition
		Min.	Typ.	Max.		
E Cycle Time	t _C	400	-	-	ns	Pin E
E Pulse Width	t _{PW}	150	-	-	ns	Pin E
E Rise/Fall Time	t _R , t _F	-	-	25	ns	Pin E
Address Setup Time	t _{SP1}	30	-	-	ns	Pins: RS, R/W, E
Address Hold Time	t _{HD1}	10	-	-	ns	Pins: RS, R/W, E
Data Setup Time	t _{SP2}	40	-	-	ns	Pins: DB0 - DB7
Data Hold Time	t _{HD2}	10	-	-	ns	Pins: DB0 - DB7

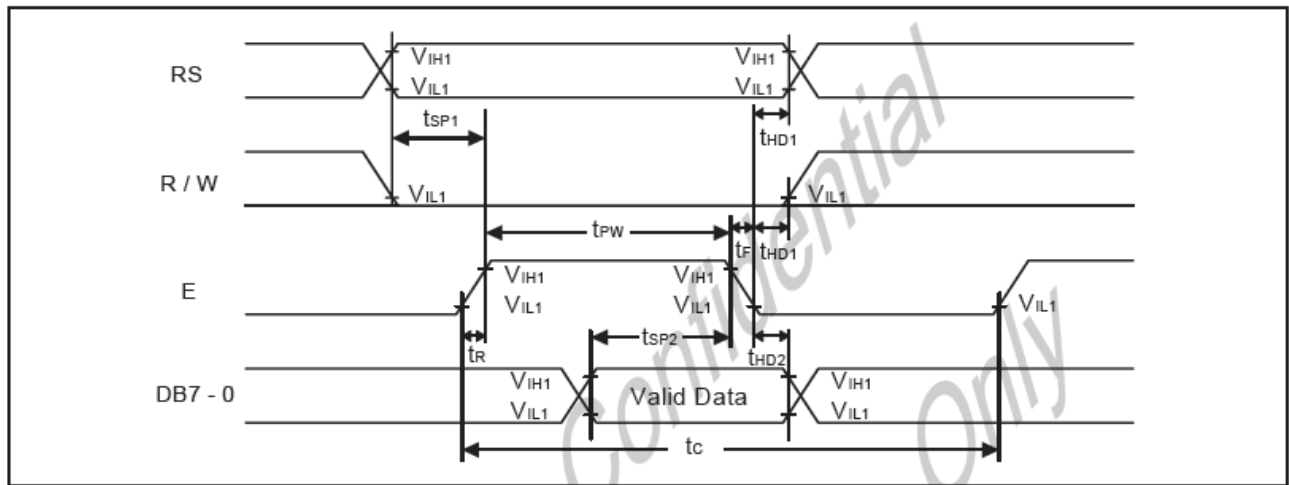

Figure 3. Write Mode Timing Diagram

Read mode (reading data from SPLC780D to MPU)

Characteristics	Symbol	Limit			Unit	Test Condition
		Min.	Typ.	Max.		
E Cycle Time	t_c	400	-	-	ns	Pin E
E Pulse Width	t_w	150	-	-	ns	Pin E
E Rise/Fall Time	t_r, t_f	-	-	25	ns	Pin E
Address Setup Time	t_{SP1}	30	-	-	ns	Pins: RS, R/W, E
Address Hold Time	t_{HD1}	10	-	-	ns	Pins: RS, R/W, E
Data Output Delay Time	t_D	-	-	100	ns	Pins: DB0 - DB7
Data hold time	t_{HD2}	5.0	-	-	ns	Pin DB0 - DB7

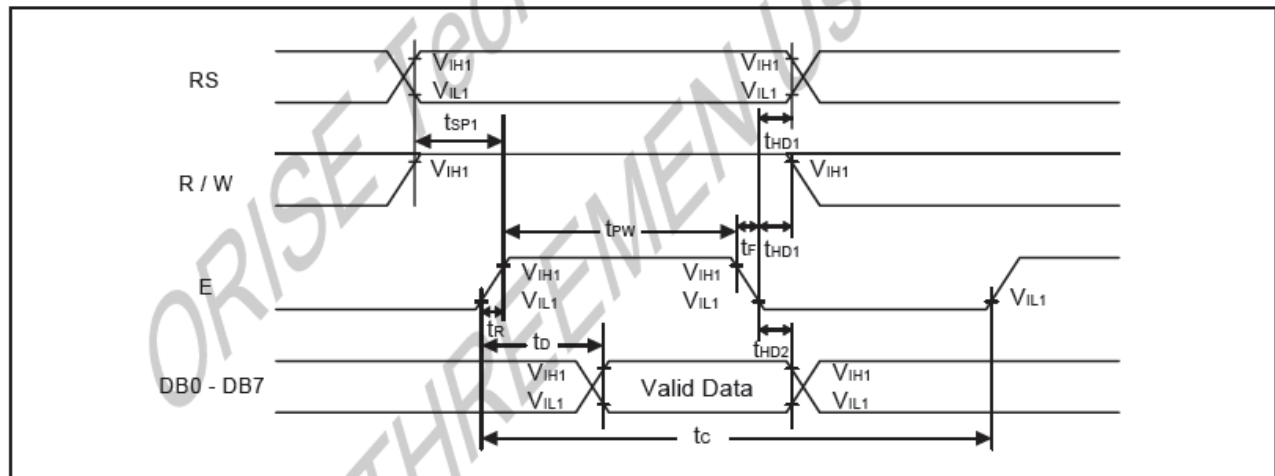

Figure 4. Read Mode Timing Diagram

Interface mode with LCD driver

Characteristics	Symbol	Limit			Unit	Test Condition
		Min.	Typ.	Max.		
Clock pulse width high	t_{PWH}	800	-	-	ns	Pins: CL1, CL2
Clock pulse width low	t_{PWL}	800	-	-	ns	Pins: CL1, CL2
Clock setup time	t_{CSP}	500	-	-	ns	Pins: CL1, CL2
Data setup time	t_{DSP}	300	-	-	ns	Pins: D
Data hold time	t_{HD}	300	-	-	ns	Pins: D
M delay time	t_D	-1000	-	1000	ns	Pins: M

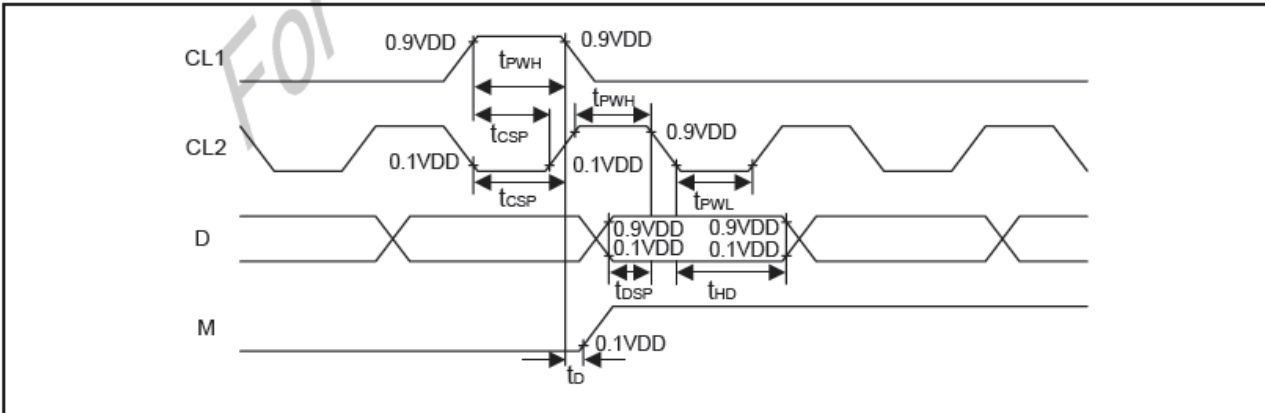

Figure 5. Interface Mode With Extension Driver Timing Diagram

8. BACKLIGHT CHARACTERISTICS

LCD Module with Bottom Yellow Green LED Backlight

Ta = 25°C

Item	Symbol	Condition	Min	Typ	Max	Unit
Forward Voltage	VF	IF=120mA	---	4.2	---	V
Reverse Current	IR	VR=10.0V	---	120	---	uA
Luminous Intensity(Without LCD)	Lv	IF=120mA	---	200	---	cd/m ²
Dominant wave length	λ_p	IF=120mA	568	572	575	nm
Color	Yellow Green					

Note:

Note: when the temperature exceed 25°C, the approved current decrease rate for backlight change as the temperature increase is: $-0.36 \times 12 \text{mA}/^\circ\text{C}$ based on the maximum absolute limiting current of the backlight, to make sure the backlight current $\leq \min[120 \text{mA}, 25 \times 12 - 0.36 \times 12 \times (T_a - 25) \text{mA}]$ (below 25°C, the current refer to constant, which would not change with temperature).

9. ELECTRO-OPTICAL CHARACTERISTICS

($T_a = 25^\circ\text{C}$)

Item	Symbol	Condition	Min	Typ	Max	Unit
Operating Voltage	Vop	$T_a = -20^\circ\text{C}$	4.0	4.2	4.4	V
		$T_a = 25^\circ\text{C}$	3.6	3.8	4.0	
		$T_a = 70^\circ\text{C}$	3.2	3.4	3.6	
Response time	Tr	$T_a = 25^\circ\text{C}$	---	150	180	ms
	Tf		---	110	132	ms
Contrast	Cr	$T_a = 25^\circ\text{C}$ $\theta_x = \theta_y = 0$	---	4.5	---	---
Viewing angle range	θ_{x-}	Cr \geq 2	30	35	---	deg
	θ_{x+}		30	35	---	deg
	θ_{y-}		35	40	---	deg
	θ_{y+}		35	40	---	deg

$$Cr = \frac{\text{Brightness of non-selected segment}(B2)}{\text{Brightness of selected segment}(B1)}$$

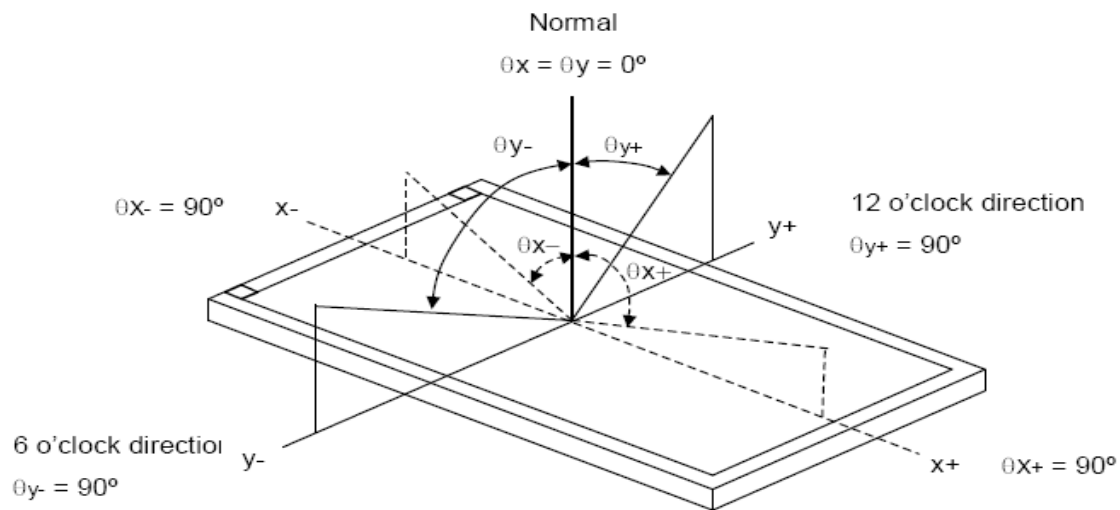
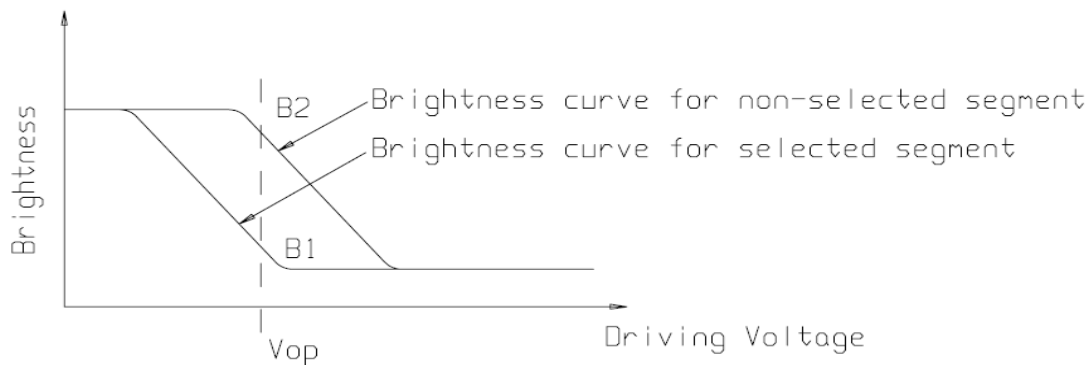

10. CONTROL AND DISPLAY INSTRUCTION

Instruction	Instruction Code										Description	Execution time (Temp = 25°C)			
	RS	RW	DB7	DB6	DB5	DB4	DB3	DB2	DB1	DB0		Fosc= 190KHz	Fosc= 270KHz	Fosc= 350KHz	
Clear Display	0	0	0	0	0	0	0	0	0	1	Write "20H" to DDRAM and set DDRAM address to "00H" from AC	2.16ms	1.52ms	1.18ms	
Return Home	0	0	0	0	0	0	0	0	0	1	Set DDRAM address to "00H" from AC and return cursor to its original position if shifted. The contents of DDRAM are not changed.	2.16ms	1.52ms	1.18ms	
Entry Mode Set	0	0	0	0	0	0	0	0	1	I/D	S	Assign cursor moving direction and enable the shift of entire display	53μs	38μs	29μs
Display ON/OFF Control	0	0	0	0	0	0	0	1	D	C	B	Set display (D), cursor(C), and blinking of cursor(B) on/off control bit.	53μs	38μs	29μs
Cursor or Display Shift	0	0	0	0	0	0	1	S/C	R/L	-	-	Set cursor moving and display shift control bit, and the direction, without changing of DDRAM data.	53μs	38μs	29μs
Function Set	0	0	0	0	0	1	DL	N	F	-	-	Set interface data length (DL: 8-bit/4-bit), numbers of display line (N: 2-line/1-line) and, display font type (F:5x10 dots/5x8 dots)	53μs	38μs	29μs
Set CGRAM Address	0	0	0	1	AC5	AC4	AC3	AC2	AC1	AC0		Set CGRAM address in address counter.	53μs	38μs	29μs
Set DDRAM Address	0	0	1	AC6	AC5	AC4	AC3	AC2	AC1	AC0		Set DDRAM address in address counter	53μs	38μs	29μs
Read Busy Flag and Address Counter	0	1	BF	AC6	AC5	AC4	AC3	AC2	AC1	AC0		Whether during internal operation or not can be known by reading BF. The contents of address counter can also be read.			
Write Data to RAM	1	0	D7	D6	D5	D4	D3	D2	D1	D0		Write data into internal RAM (DDRAM/CGRAM).	53μs	38μs	29μs
Read Data from RAM	1	1	D7	D6	D5	D4	D3	D2	D1	D0		Read data from internal RAM (DDRAM/CGRAM).	53μs	38μs	29μs

Note1: "-": don't care

Note2: In the operation condition under -20°C ~ 75°C, the maximum execution time for majority of instruction sets is 100us, except two instructions, "Clear Display" and "Return Home", in which maximum execution time can take up to 4.1ms.

11. FONT CHARACTERISTIC

Upper 4 bit Lower 4 bit	LLLL	LLLH	LLHL	LLHH	LHLL	LHLH	LHHL	LHHH	HLLL	HLLH	HLHL	HLHH	HHLL	HHLH	HHHL	HHHH
LLLL				0	1	2	3	4					一	夕	三	㊦
LLLH			!	1	A	Q	a	9			。	ア	チ	△	㊦	㊦
LLHL			"	2	B	R	b	r			"	イ	ウ	×	㊦	㊦
LLHH			#	3	C	S	c	s			」	ウ	テ	㊦	㊦	㊦
LHLL			\$	4	D	T	d	t			、	エ	ト	㊦	㊦	㊦
LHLH			%	5	E	U	e	u			・	オ	大	㊦	㊦	㊦
LHHL			&	6	F	U	f	u			㊦	カ	ニ	㊦	㊦	㊦
LHHH			'	7	G	W	g	w			㊦	キ	又	㊦	㊦	㊦
HLLL			(8	H	×	h	×			㊦	㊦	㊦	㊦	㊦	㊦
HLLH)	9	I	Y	i	y			㊦	㊦	㊦	㊦	㊦	㊦
HLHL			*	*	J	Z	j	z			㊦	コ	㊦	㊦	㊦	㊦
HLHH			+	+	K	K	㊦	㊦			㊦	㊦	㊦	㊦	㊦	㊦
HHLL			,	<	L	㊦	㊦	㊦			㊦	㊦	㊦	㊦	㊦	㊦
HHLH			=	=	M	J	n	㊦			㊦	㊦	㊦	㊦	㊦	㊦
HHHL			.	>	N	㊦	n	㊦			㊦	㊦	㊦	㊦	㊦	㊦
HHHH			/	?	O	L	o	㊦			㊦	㊦	㊦	㊦	㊦	㊦

12. PRECAUTION FOR USING LCD/LCM

LCD/LCM is assembled and adjusted with a high degree of precision. Do not attempt to make any alteration or modification. The followings should be noted.

General Precautions:

1. LCD panel is made of glass. Avoid excessive mechanical shock or applying strong pressure onto the surface of display area.
2. The polarizer used on the display surface is easily scratched and damaged. Extreme care should be taken when handling. To clean dust or dirt off the display surface, wipe gently with cotton, or other soft material soaked with isopropyl alcohol, ethyl alcohol or trichlorotrifluoroethane, do not use water, ketone or aromatics and never scrub hard.
3. Do not tamper in any way with the tabs on the metal frame.
4. Do not make any modification on the PCB without consulting AGT .
5. When mounting a LCM, make sure that the PCB is not under any stress such as bending or twisting. Elastomer contacts are very delicate and missing pixels could result from slight dislocation of any of the elements.
6. Avoid pressing on the metal bezel, otherwise the elastomer connector could be deformed and lose contact, resulting in missing pixels and also cause rainbow on the display.
7. Be careful not to touch or swallow liquid crystal that might leak from a damaged cell. Any liquid crystal adheres to skin or clothes, wash it off immediately with soap and water.

Static Electricity Precautions:

1. CMOS-LSI is used for the module circuit; therefore operators should be grounded whenever he/she comes into contact with the module.
2. Do not touch any of the conductive parts such as the LSI pads; the copper leads on the PCB and the interface terminals with any parts of the human body.
3. Do not touch the connection terminals of the display with bare hand; it will cause disconnection or defective insulation of terminals.
4. The modules should be kept in anti-static bags or other containers resistant to static for storage.
5. Only properly grounded soldering irons should be used.
6. If an electric screwdriver is used, it should be grounded and shielded to prevent sparks.
7. The normal static prevention measures should be observed for work clothes and working benches.
8. Since dry air is inductive to static, a relative humidity of 50-60% is recommended.

Soldering Precautions:

1. Soldering should be performed only on the I/O terminals.
2. Use soldering irons with proper grounding and no leakage.
3. Soldering temperature: 270~300°C
4. Soldering time: 2 to 3 second.
5. Use eutectic solder with resin flux filling.
6. If flux is used, the LCD surface should be protected to avoid spattering flux.
7. Flux residue should be removed.

Operation Precautions:

1. The viewing angle can be adjusted by varying the LCD driving voltage V_o .
2. Since applied DC voltage causes electro-chemical reactions, which deteriorate the display, the applied pulse waveform should be a symmetric waveform such that no DC component remains. Be sure to use the specified operating voltage.
3. Driving voltage should be kept within specified range; excess voltage will shorten display life.
4. Response time increases with decrease in temperature.
5. Display color may be affected at temperatures above its operational range.
6. Keep the temperature within the specified range usage and storage. Excessive temperature and humidity could cause polarization degradation, polarizer peel-off or generate bubbles.
7. For long-term storage over 40°C is required, the relative humidity should be kept below 60%, and avoid direct sunlight.

Limited Warranty

AGT LCDs and modules are not consumer products, but may be incorporated by AGT customers into consumer products or components thereof, AGT does not warrant that its LCDs and components are fit for any such particular purpose.

1. The liability of AGT is limited to repair or replacement on the terms set forth below. AGT will not be responsible for any subsequent or consequential events or injury or damage to any personnel or user including third party personnel and/or user. Unless otherwise agreed in writing between AGT and the customer, AGT will only replace or repair any of its LCD which is found defective electrically or visually when inspected in accordance with AGT general LCD inspection standard . (Copies available on request)
2. No warranty can be granted if any of the precautions state in handling liquid crystal display above has been disregarded. Broken glass, scratches on polarizer mechanical damages as well as defects that are caused accelerated environment tests are excluded from warranty.\
1. In returning the LCD/LCM, they must be properly packaged; there should be detailed description of the failures or defect.

13. LCM TEST CRITERIA(A1 LEVEL)

1. Objective

The LCM test criteria are set to formalize AGT quality standards with reference to those of the customer for inspection, release and acceptance of finished LCM products in order to guarantee the quality required by the customer.

2. Scope

The criteria are applicable to all the LCM products manufactured by AGT.

3. Equipments for Inspection

Electrical testing machines, vernier calipers, ampere meter, multi-meter, microscopes, anti-static wrist straps, finger cots, labels, tri-phase thermal shock chamber, constant temperature and humidity chamber, high-low temperature experimenting box, refrigerators, constant voltage power supply (DC)), desk Lamps, etc.

4. Sampling Plan and Reference Standards

4.1.1 Based on GB/T 2828.1---2003/ISO2859-1:1999:

Inspection items	Sampling Rate	AQL Assessment
Appearance	Normally checking the sampling plan one time and performing general inspection level II	MA=0.4 MI=1.0
Function	Normally checking the sampling plan one time and performing general inspection level II	MA=0.4 MI=1.0
Size	N=3	C=0

4.1.2 GB/T 2828.1---2003/ISO2859-1:1999 checking the counting sampling procedure and sampling table.

4.1.3 GB/T 1619.96: Test methods for TN LCD parts.

4.1.4 GB/T 12848.91: General Specification for STN LCD parts

4.1.5 GB2421-89: Basic Environmental Test Procedures for Electrical and Electronic Products

4.1.6 IPC-A-610C: The acceptance condition for electrician assembled.

5. Inspection Conditions and Inspection Reference

5.1 Cosmetic inspection: shall be done normally at $25\pm 5^{\circ}\text{C}$ of the ambient temperature and $45\pm 20\%$ RH of relative humidity, under the ambient luminance greater than 300lux and at the distance of 30cm apart between the inspector's eyes and the LCD panel and normally in reflected light. For back-lit LCMs, cosmetic inspection shall be done under the ambient luminance less than 100lux with the backlight on.

5.2 The LCM shall be tested at the angle of 45° , left and right, and $0-45^{\circ}$, top and bottom (for STN LCM, at $20^{\circ}-55^{\circ}$) :

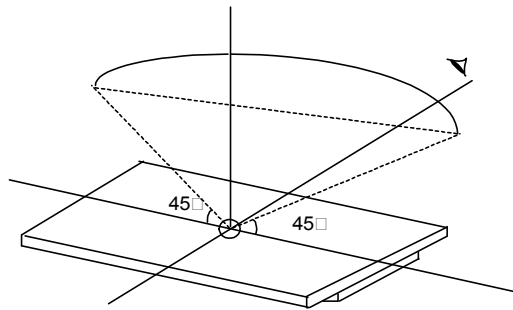

5.3 Definition of VA

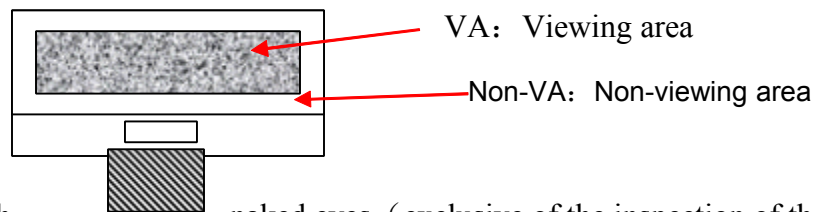

5.4 Inspection with naked eyes (exclusive of the inspection of the physical dimensions of defects carried out with magnifiers) .

5.5 Electrical properties: Inspection with the self-made/special LCM test jigs against the product documents or drawings; display contents and parameters shall conform to their documents requirements and the display effect to the drawing.

5.5.1 Test voltage (V) : (Determined) according to the operating instruction of test jigs assuming the external circuit can be adjusted unless the customer otherwise specifies driving voltage(s). (Display) effects are controlled within the specified range of voltage variation (If no specific requirements, display effects are controlled at $V_{op} = 9\text{V}$ or $V_{op} \pm 0.3\text{V}$ when V_{op} is below 9V; if V_{op} is above 9V, display effects are controlled at $V_{op} \pm 0.3\%$ at least). For display products with the customer-specified fixed V_{op} , display effects are controlled by adjusting the internal circuit; if necessary, acceptable limit samples shall be built.

5.5.2 Current Consumption (I) : Refer to approved product specifications or drawings.

5.5.3 Size: for the outline dimension and the position which may affect customer assembled all should conform to the technical drawing requirements.

6. Defects and Acceptance Standards

6.1 Electrical properties test

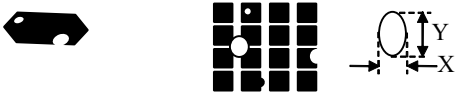
No.	Defects	Description	Accepted standard	MAJ	MIN
6.1.1	Missing segmet	SEG/COM dot and character missing segment caused by its wire broken/poor contact(s) and internal open circuit. 	Reject	√	
6.1.2	No display/ reaction	The products no picture display under normally connected situation.	Reject	√	
6.1.3	Mis-dispaly/ abnormaly display	Displaying pattern and sequence not conform to the requirement or abnormally display when scanning as per the correct procedure.	Reject	√	
6.1.4	Wrong viewing angle	When powered on, the clearest viewing direction of display pattern is not conform to the requested one(or not conform the direction of the customer approved samples)	Reject	√	
6.1.5	Dim or dark display	Overall contrast is either too dark or too dim under normal operation	Beyond the voltage tolerance, reject	√	
6.1.6	Responded slowly	When power on or off some parts response time is different from others.	Reject	√	
6.1.7	Exceed segment	As misalignment and insufficient etching caused abnormally display, display with exceed pattern or display with abnormally symbol, row or columns when power on.	Refer to the dot/line standard		√
6.1.8	Dim segment	Under the normal voltage, the contrast of vertical and horizontal segments is uneven and the depth of display segments with different contrast ratio.	Reject or refer to its samples		√
6.1.9	PI black/ white spot	Partial black and white spots visible when changing display contents due to defective PI layer in the inner of LCD.	Refer to the spot/line criteria for the visible spots when display image remains still; others OK		√
6.1.10	Pinhole /white spot	Fragmental patterns appearing when it powered on caused by missing ITO.  $d = (X+Y)/2$	Refer to the dot/line standard		√

6.1.11	Partten distortion	The pattern displayed width is either wider, narrower or deformed than the specified, caused by its misalignment and resulting in unwanted heave(s) or missing: $ a-b \leq 1/4W$ (W is the normal width) 	$ a-b >1/4W$, Reject		√
6.1.12	High current	The current of LCD is higher than the standard one.	Reject		√
6.1.13	Cross talk	The degree of cross talk should not beyond the limited samples.	Refer to its limited samples	√	

6.2 LCD appearance defect:

6.2.1 Dot and line defects (defined within VA, spots out of VA do not account)

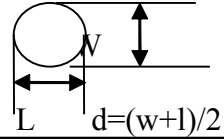
No.	Defects	Average diameter (d)	Acceptable quantity	MAJ	MIN
6.2.1.1	Spot defects (black spot, foreign material, nick, scratches, including LC with wrong orientation)	$d\leq 0.20$	3		√
		$0.20<d\leq 0.25$	2		
		$0.25<d\leq 0.30$	1		
		$0.30<d$	0		
6.2.1.2	Line defects (scratches and line with foreign materials)  Line length=L Line width=W	$W\leq 0.01$	Not counted		√
		$L\leq 3.0, W\leq 0.02$	3		
		$L\leq 3.0, W\leq 0.03$	3		
		$L\leq 3.0, W\leq 0.05$	1		
		Note: when $W>0.1\text{mm}$ it can regard as spot defect one.			
6.2.1.3	Polarizer with air bubble or convex-concave dots defect 	$d\leq 0.3$	3		√
		$0.3<d\leq 0.5$	2		
		$0.5<d\leq 0.8$	0		
Note: each of the same product should not exceed with 4 spot and line defects and the distance between each two spot should $\geq 5\text{mm}$.					

6.2.2 Glass Damages (for LCMs without bezels and whose LCD edges exposed and for LCMs with bezels, including COG, H/S and directly assembled with BL LCMs)

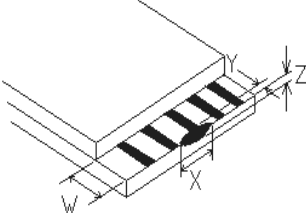
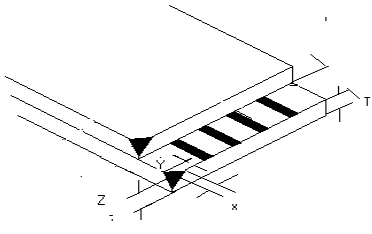
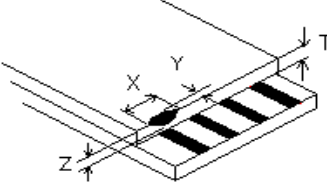
No.	Defects	Acceptance Standard (unit : mm)		MAJ	MIN
6.2.2.1	chipping on conductive angle 	X	≤ 3.0		√
		Y	$\leq 1/3W$		
		Z	$\leq 1/2t$		
		Acceptable quantity	2		
		When $Y \leq 0.2\text{mm}$, the length of X doesn't count; for chip neither on lead nor through, when $X \leq 1/10L$, $Y \leq 1/2W$ max, it doesn't count.			
6.2.2.2	chip on corner(ITO lead) 	X	$\leq 1/10L$		√
		Y	$\leq 2/3W$		
		Z	$\leq t$		
		Acceptable quantity	2		
		For chips on the end sealing corners, refer to 6.2.2.3 and they must be out of the frame epoxy. For chips on lead, refer to 6.2.2.1			
6.2.2.3	Chip on sealed area (outer chip) 	X	$\leq 1/8L$		√
		Y	$\leq 1/2H$		
		Z	$\leq 1/2t$		
		Acceptable quantity	2		
		The standard for inner chip on sealed area is the same as the standard for outer. For chip on the reverse of ITO contact pad ledge, refer to 6.2.2.1 for chip on the reverse of ITO contact pad ledge for the value of Y.			
Note: X means the length of chip; Y means the width of the chip; Z means the thickness of the chip; W means the width of the stage of the two glasses; L means the length of the glass; H means the distance between the glass edge and the inner side of frame glue; t means the thickness of the glass.					

6.2.3 Others

No.	Defects	Description	Acceptance standard	MAJ	MIN
6.2.3.1	Rain ball/ bottom color	There is two different color in the same one product or the same batch products with two different colors	Reject or refer to the limited samples		√
6.2.3.2	Leaking ink (LC)	/	Reject	√	
6.2.3.3	Without protect film	/	Reject		√
6.2.3.4	Splay mark	Inspecting whether the surface of polarizer with splay marks against the light	Refer to the limited samples		√

6.3 Backlight components:

No.	Defects	Description	Acceptance standard	MAJ	MIN
6.3.1	Backlight not working, wrong color	/	Reject	√	
6.3.2	Color deviation	When powered on, the LCD color differs from its sample and found that the color not conforming to the drawing after testing.	Refer to sample and drawing		√
6.3.3	Brightness deviation	When powered on, the LCD brightness differs from its sample and is found after testing not conforming to the drawing; or if it conforms to the drawing but the brightness over $\pm 30\%$ than its sample.	Refer to sample and drawing		√
6.3.4	Uneven brightness	When powered on, the LCD brightness is uneven on the same LCD and out of the specification of the drawing. The no specification evenness= (the max value-the min value)/ mean value $< 70\%$.	Refer to sample and drawing		√
6.3.5	Spot/line scratch	When power on, it with dirty spot, scratches and so on spot and line defects	Refer to 6.2.1		√
6.3.6	BL wrapped	The BL should paste tightly on the PCB.	The BL can be allowed within 1mm wrapped parts, if them not affect its appearance and outline dimension.		√
6.3.7	Flicker and with LED shade	When power on, each bright source should not with flicker and the brightness should evenness and without LED shades.	Reject	√	

6.4 Metal frame (Metal Bezel)

No.	Defects	Description	Acceptance standard	MAJ	MIN
6.4.1	Material/surface treatment	Metal frame/surface treatment do not conform to the specifications.	Reject	√	
6.4.2	Tab twist inconformity/	Wrong twist method or direction and twist tabs are not twisted as required.	Reject	√	

	Tab not twisted				
6.4.3	Oxidization	Oxidation on the surface of the metal bezel	Reject		√
6.4.4	Painting peel off, discoloration, dents, and scratches	1) the front surface with painting peel off and scratched can be see the bottom: Dot : $D \leq 0.5\text{mm}$, exceeds 3; Line: length $\leq 3.0\text{mm}$, width $\leq 0.05\text{mm}$, exceeds 2; 2) front dent, air bubble and side with painting peel off which scratched can be see the bottom: Dot: $D \leq 1.0\text{mm}$, exceeds 3; Line: length $\leq 3.0\text{mm}$, width $\leq 0.05\text{mm}$, exceeds 2.	Reject		√
6.4.5	Burr	Burr(s) on metal bezel is so long as to get into viewing area.	Reject		√

6.5 PCB/COB

No.	Defects	Description	Acceptance standard	MAJ	MIN
6.5.1	Improper Epoxy Cover	1) Contacts exposure within the white circle for COB chip bonding. 2) The height of epoxy cover is out of the product specifications and drawing. 3) The epoxy cover over the COB chip exceeds the circle by more than 2mm in diameter, which is the maximum distance the epoxy cover is allowed to exceed the circle. 4) Existence of obvious linear mark(s) or chip-exposing pinhole on the epoxy cover. 5) The pinhole diameter on the epoxy over exceeds 0.25mm and there is foreign matter in the pinhole.	Reject		√
6.5.2	PCB appearance defect	1) Oxidized or contaminated gold fingers on PCB. 2) Bubbles on PCB after reflow-soldering. 3) Exposure of conductive copper foil caused by peeled off or scratched solder-resist coating. For the conductive area of PCB repaired with the solder resist coating material, the diameter ψ of the repaired area on the circuit must not exceed 1.3mm while for the non-conductive area of PCB repaired with the solder resist coating material, the diameter ψ must not exceed 2.6mm; the total number of repaired	Reject		√

		areas on PCB must be less than 10; otherwise, the PCB must be rejected.			
6.5.3	Wrong or missing Components on PCB	<p>1) Components on PCB are not the same as defined by drawing such as wrong, excessive, missing, or mis-polarized components. (The bias circuit of LCD voltage or the backlight current limiting resistance is not adjusted unless specified by the customer.)</p> <p>2) The JUMP short on PCB shall conform to the mechanical drawing. If excessive or missing soldering occurs, the PCB shall be rejected.</p> <p>3) For components particularly required by the customer and specified in the mechanical drawing and/or component specifications, their specifications must conform to those of the suppliers; otherwise they shall be rejected.</p>	Reject	√	

6.6 Connector and other components

No.	Defects	Description	Acceptance standard	MAJ	MIN
6.6.1	Out of Specification	The specification of connector and other components do not conform to the drawing.	Reject		√
6.6.2	Position and order	Solder position and Pin# 1 should be in the positions specified by the drawing.	Reject		√
6.6.3	Appearance	<p>1) Flux on PCB components and pins.</p> <p>2) The pin width of a PIN connector exceeds ½ of the specified pin width.</p>	Reject		√
6.6.4	Glue amount	Flat cable connector: as the conducted wire fixed with glue, if the glue not fully covered the exposed wire and the copper part around holes will be rejected.	Reject		√
6.6.5	Through holes blocked	Socket connector: the components can not plug-in units as the through holes blocked and deformation; the locks which with lock catch can not make the external connector to be locked.	Reject		√

6.7 SMT (Refer to IPC-A-610E the second standard if not specified)

No.	Defects	Description	Acceptance standard	MAJ	MIN
6.7.1	Soldering solder defects	Cold, false and missing soldering, solder crack and insufficient solder dissolution.	Reject		√
6.7.2	Solder	Solder ball/tin dross causing short circuit at	Reject		√

	ball/splash	the solder point. There are active solder ball and splash.			
6.7.3	DIP parts	Floated or tilted DIP parts, keypad, and connectors.	Reject		√
6.7.4	Solder shape	The welded spot should be concave and excessive or insufficient solder or solder burr on the welded spot must be rejected.	Reject		√
6.7.5	Component pin exposure	For the DIP type components, 0.5~2mm component pin must be remained after cutting the soldered pin and the solder surface neither should not be damaged nor should the component pin is fully covered with solder; otherwise rejected.	Reject		√
6.7.6	Poor Appearance	The LCMs become yellow-brown or black as the residual resin or solder oil. There is white mist residual at the solder point caused by PCB cleaning.	Reject		√

6.8 Hot Pressing components (including H/S, FPC, etc.)

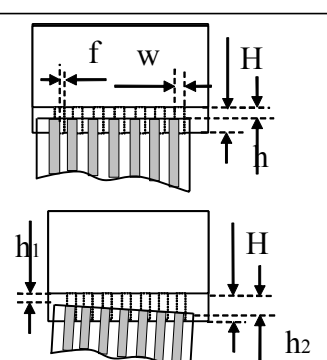
No.	Defects	Description	Acceptance standard	MAJ	MIN
6.8.1	Out of its specification		Reject	√	
6.8.2	Size		Refer to its drawing		√
6.8.3	Position	 <p>Note: H=ITO pin length, W=ITO pin width, f= heat seal or the misplaced width of TAB.</p>	<p>1, If $f \leq 1/3w$, $h \leq 1/3H$, and its conform to the size and specification on drawing, which will be received.</p> <p>2, The contact area of dielectric material conductor position and pressing material over 1/2 (controlling as per each ITO position) will be received.</p>		√
6.8.4	Foreign Matter in Hot pressing area	If foreign matter in non-conductive heat compression area shall not cause short, it is OK. If foreign matter in conductive heat compression area does not exceed 50% of the heat pressure area, it is OK.	Receive		√

6.8.5	Fold marks		Refer to the limited samples.		√
-------	------------	--	-------------------------------	--	---

6.9 General Appearance

No.	Defects	Description	Acceptance standard	MAJ	MIN
6.9.1	Connection material	Damaged or contaminated FPC or H/S gold fingers or FFC contact pin side with exposed copper foil or base materials. Sharp folds on FPC, FFC, COF, H/S (unless designed for). Solder paste larger than 2/3 of pin width on the gold finger of FPC and PCB. Pierced or folded FPC/FFC exceeding limit sample.	Reject		√
6.9.2	Poor reinforcing band	The protect tape using for reinforce which not complete covered the needed protection circuits (such as H/S, FFC, FPC, etc.) or it not joint with its pasted material or it glued on the output side of pins.	Reject		√
6.9.3	Surface dirt	The surface of finished LCMs with smudge, residual glue, and finger prints, etc; solder spatters or solder balls on non-soldered area of PCB/COB. Non-removed defect mark or label on LCMs.	Reject		√
6.9.4	Assembly black spot	Smears or black spots found on LCMs after backlight or diffusion barrier are assembled.	Refer to 6.2.1		√
6.9.5	Product mark	Missing, unclear, incorrect, or misplaced part numbers and/or batch marks.	Reject		√
6.9.6	Inner packing	Packing being inconsistent with quantity and part number on packing label, specifications or the customer order - either short-packed or over-packed.	Reject		√

7. Reliability test

Test items	Condition	Time (hrs)	Acceptable standard
Store in high temperature	80°C	240hrs	Its function and appearance qualified before and after test
Operation under high temperature	70°C		
Store in low temperature	-30°C		
Operation under low temperature	-20°C		
Humidity test	60°C,90%RH		
Temperature cycle	-30°C ←-25°C →80°C (30min←10min→30min) ,and raising its temperature 5°C/min	10 cycles	
The temperature allowable deviation is ±5°C and the humidity allowable deviation is ±5%RH.			

8. Packing

- 8.1 The acceptance inspection of product packing shall meet design requirements. The product packaging label shall bear not only product name, part number, quantity, product date code but also QA's qualifying stamp for each production stage. Incomplete or wrong label shall be unacceptable.
- 8.2 When there are problems with packing safety conformity such as shock resistance, moisture resistance, anti ESD and press resistance, packing shall be disqualified.
- 8.3 When customer's special requirements for packing confirmed and accepted by AGT packing shall be inspected and released according to them.
- 8.4 RoHS and non-RoHS compliant products shall be labeled clearly and separately. Unless otherwise specified by the customer, "RoHS" labels shall be used for all RoHS compliant products.

9. Others

- 9.1 Items not specified in this document or released on compromise should be inspected with reference to mutual agreement and limit samples.